

Wohnmodul

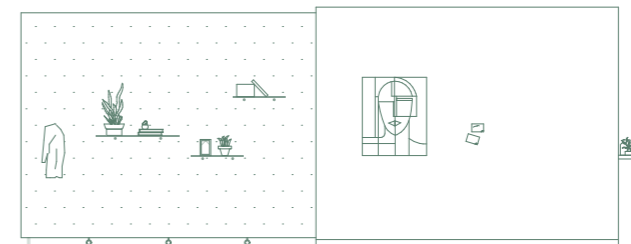

Detail Wohnraum

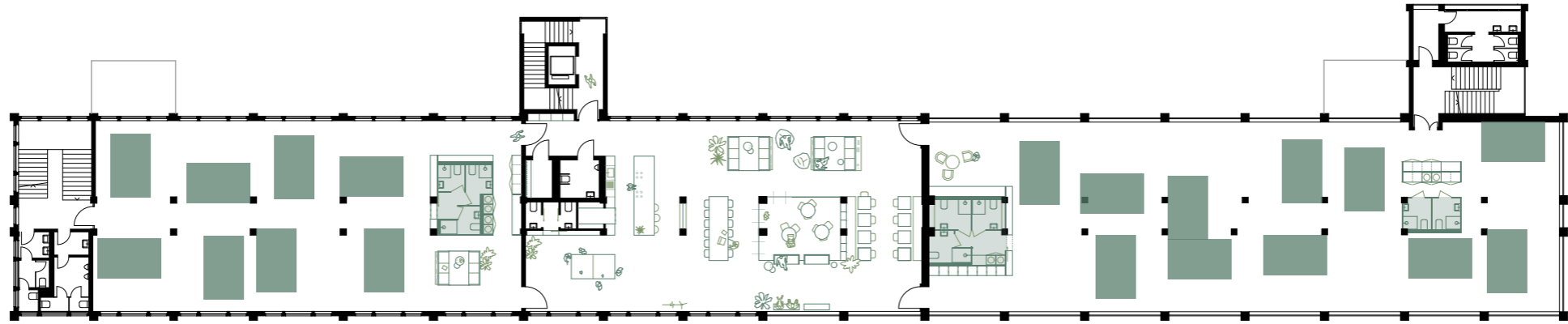
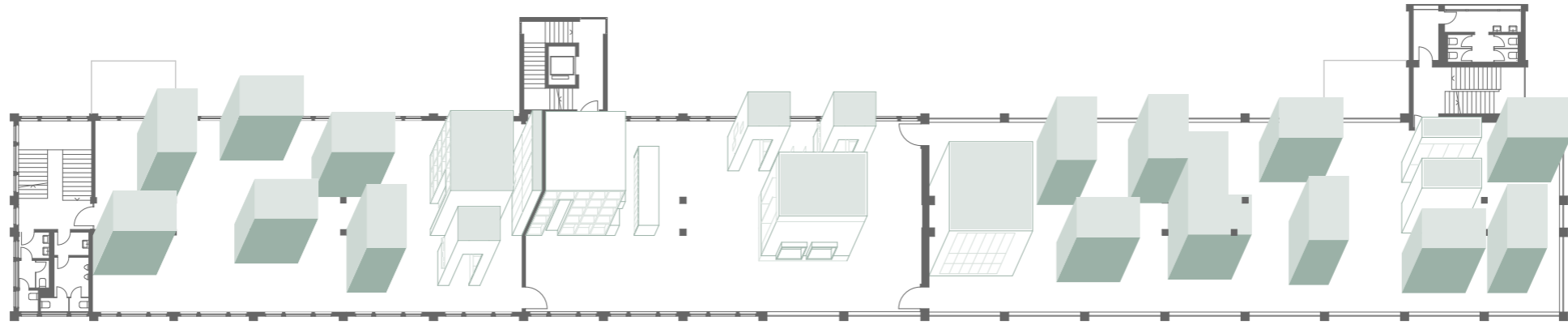

Zonierung 1.Obergeschoss

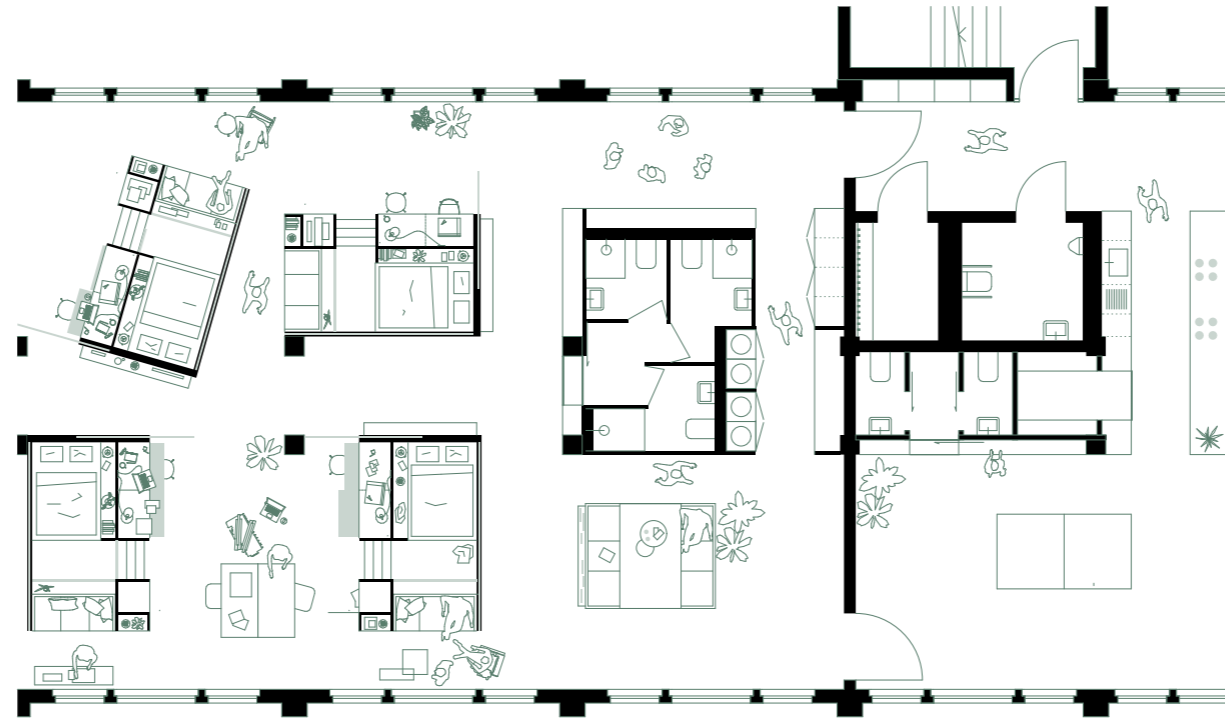

Grundriss detailliert



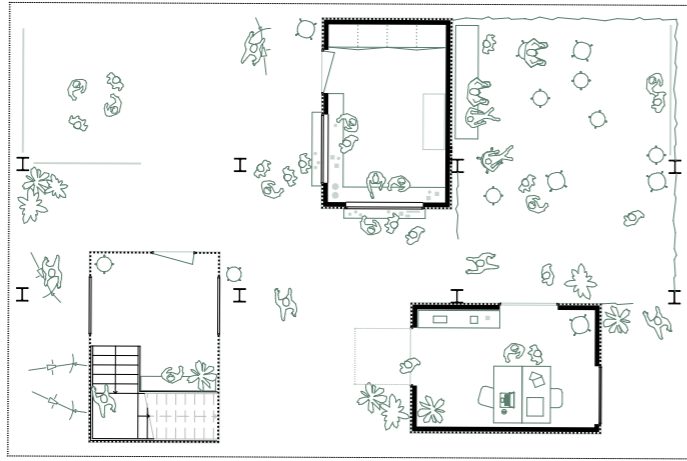

Erdgeschoss

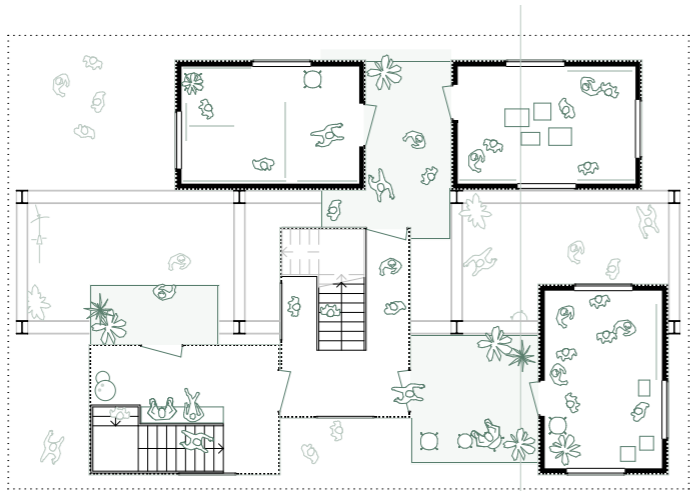

1.Obergeschoss

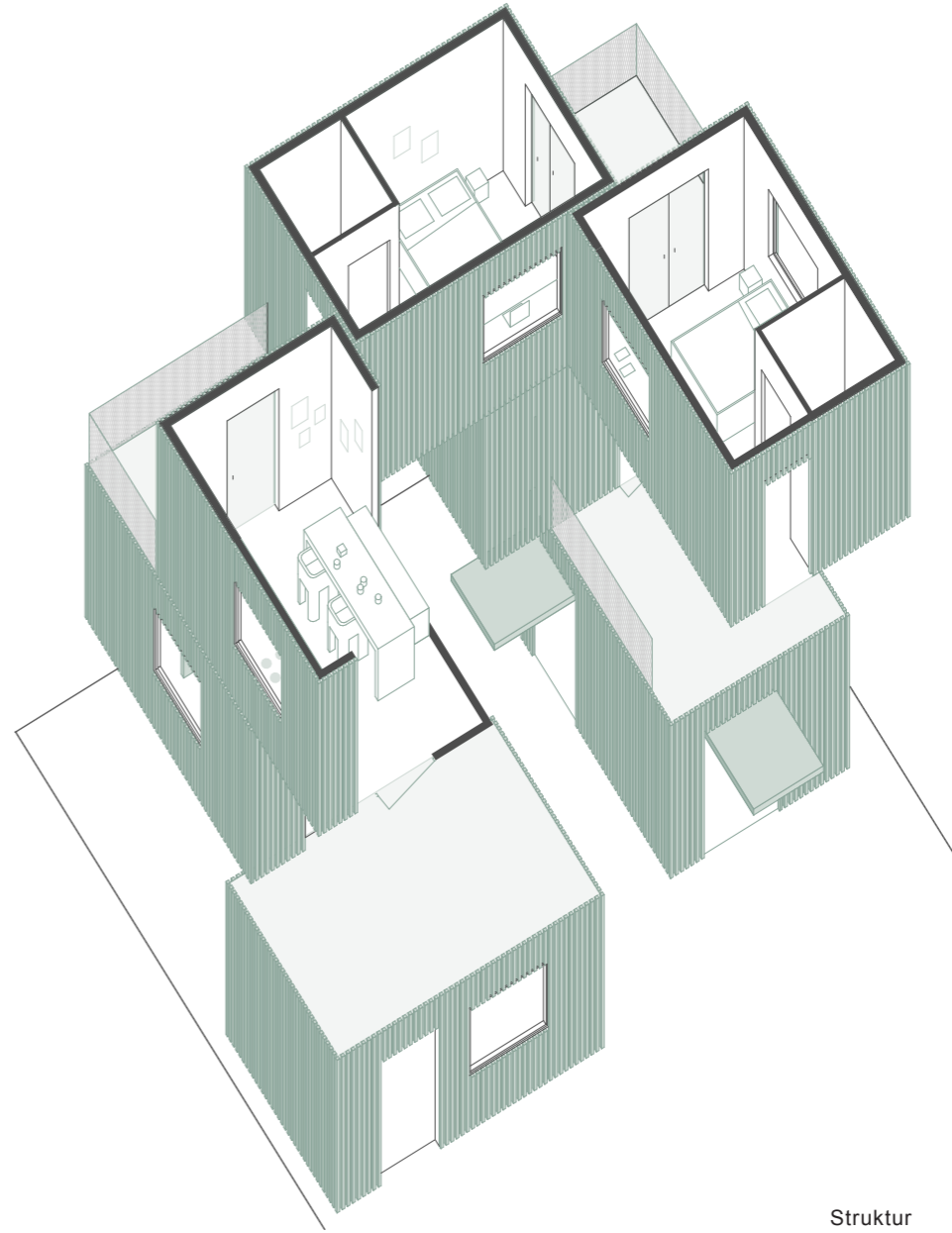

Struktur

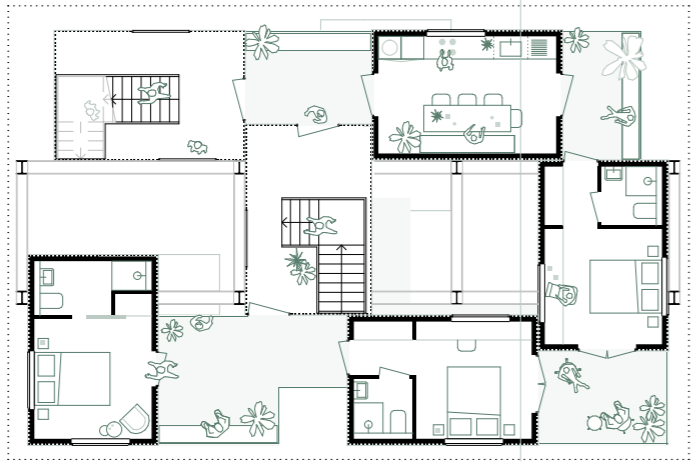

2.Obergeschoss

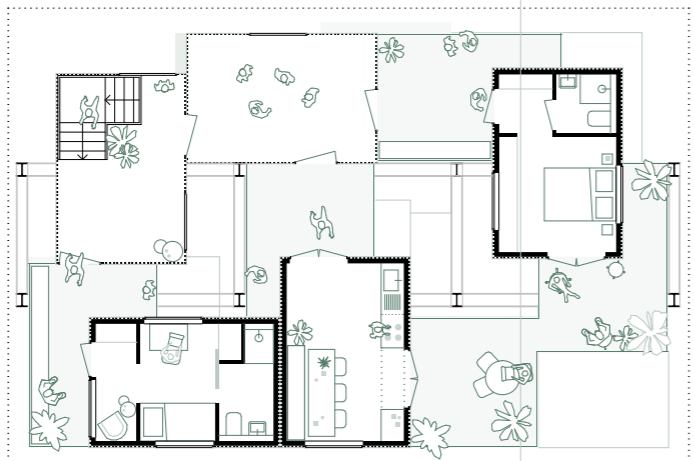

3.Obergeschoss

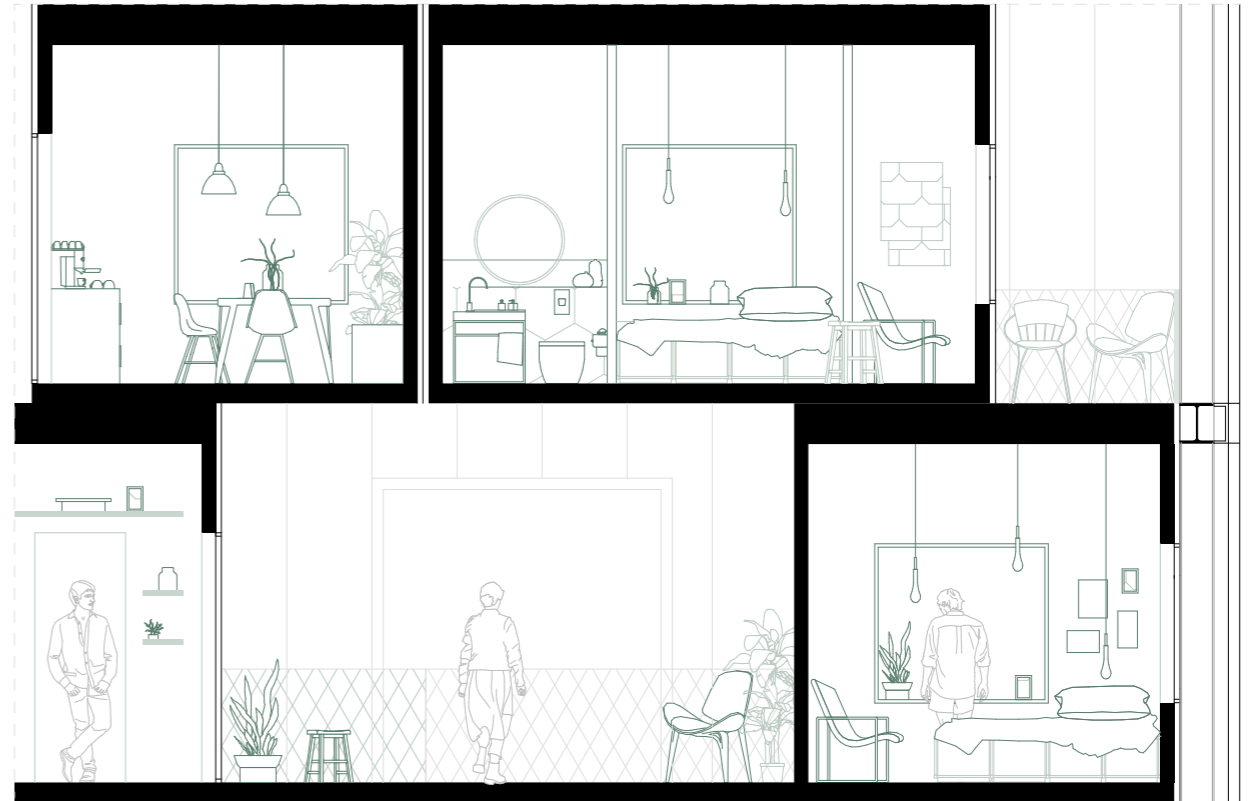

Schnitt Wohnen

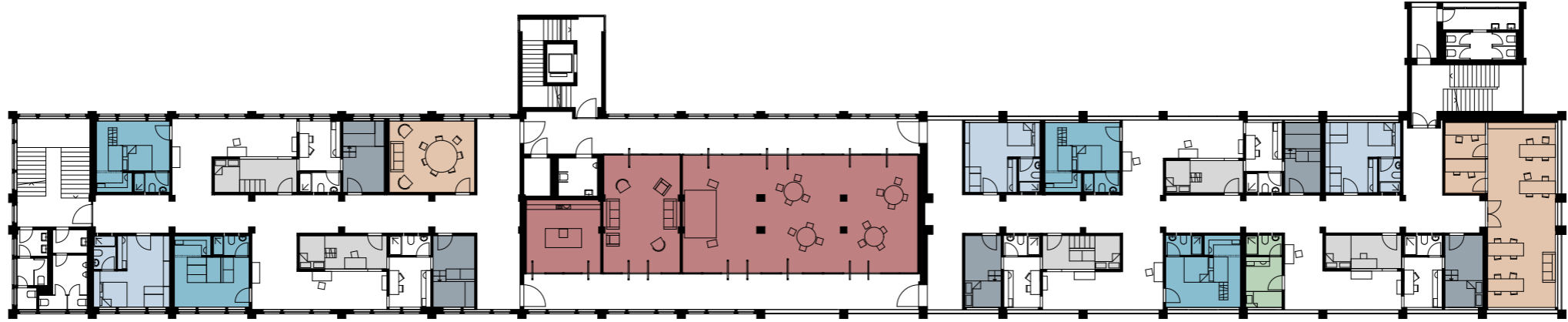

- 1.Obergeschoss
- Gemeinsam Erholen
 - Gemeinsam Arbeit
 - Single-Wohnen, Schiebemodul
 - Single-Wohnen, Klappmodul
 - Gästezimmer
 - Wohngemeinschaft, Schubladenmodul
 - Wohngemeinschaft, Ebenenmodul

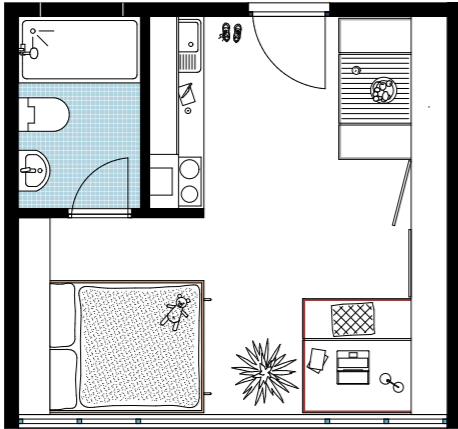

Wohneinheit mit Klappmodulen



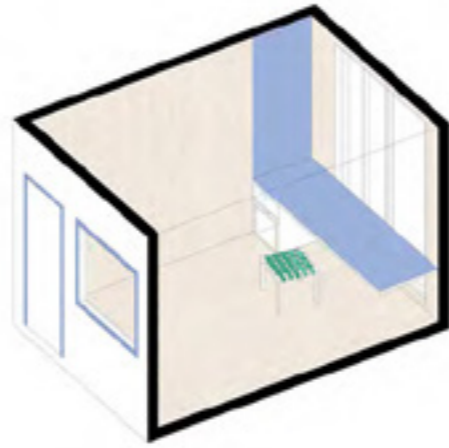

Axonometrie Carrels-Gruppenraum-Arbeitsraum



X.CAMPUS
Bauformenlehre
Diana Buterus
Hannah Ernst

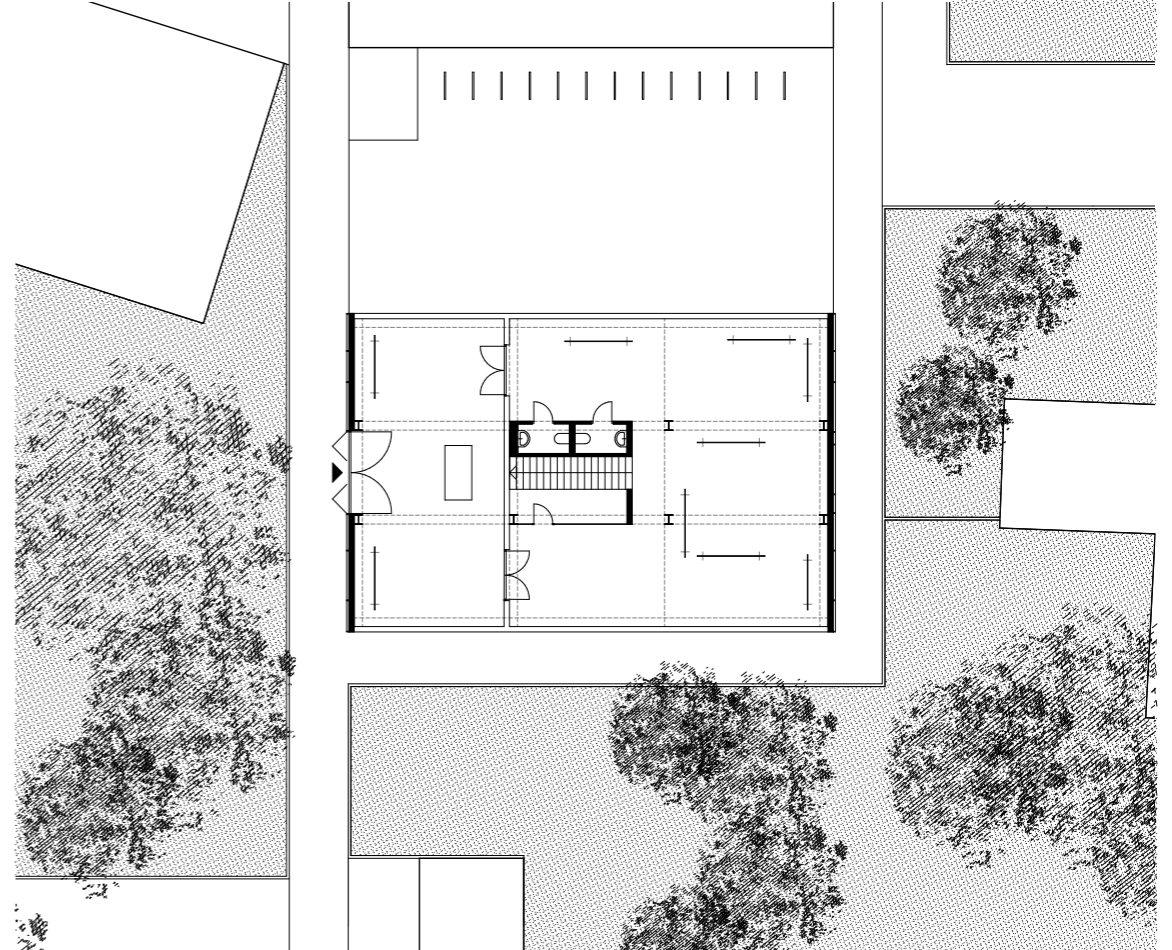

Erdgeschoss

X.CAMPUS
Bauformenlehre
Diana Buterus
Hannah Ernst

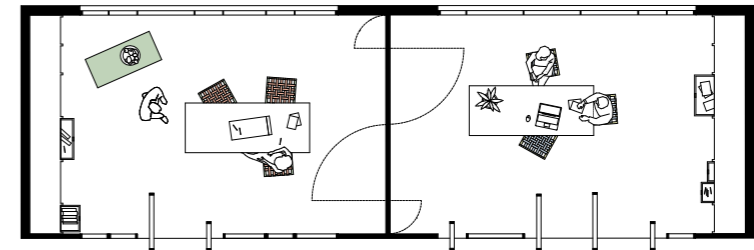
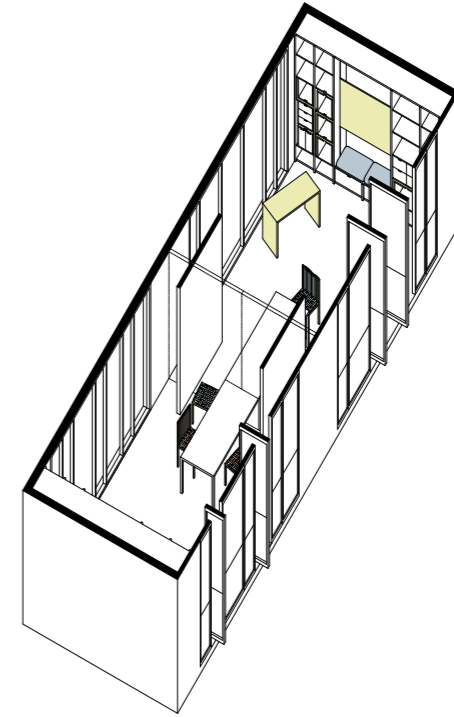

Grundriss/Axonometrie Gruppenraum

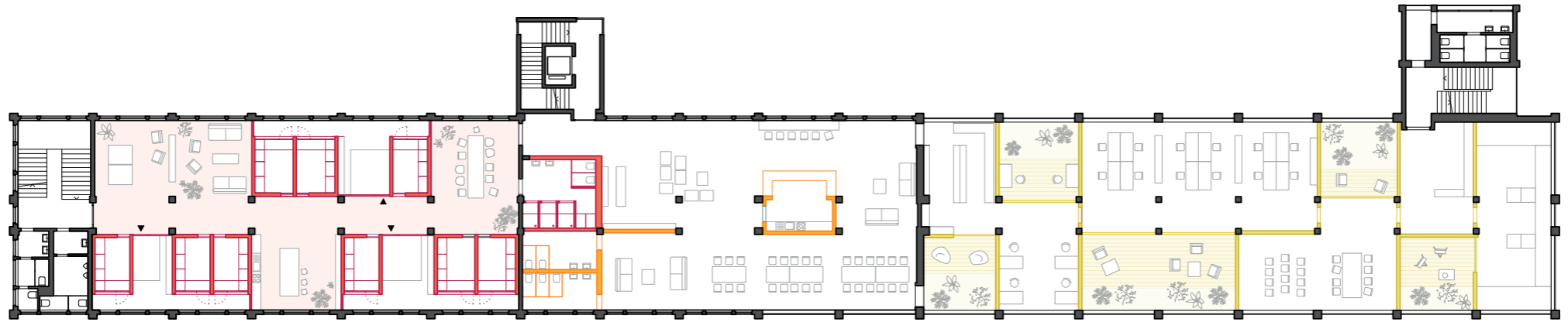

1.Obergeschoss

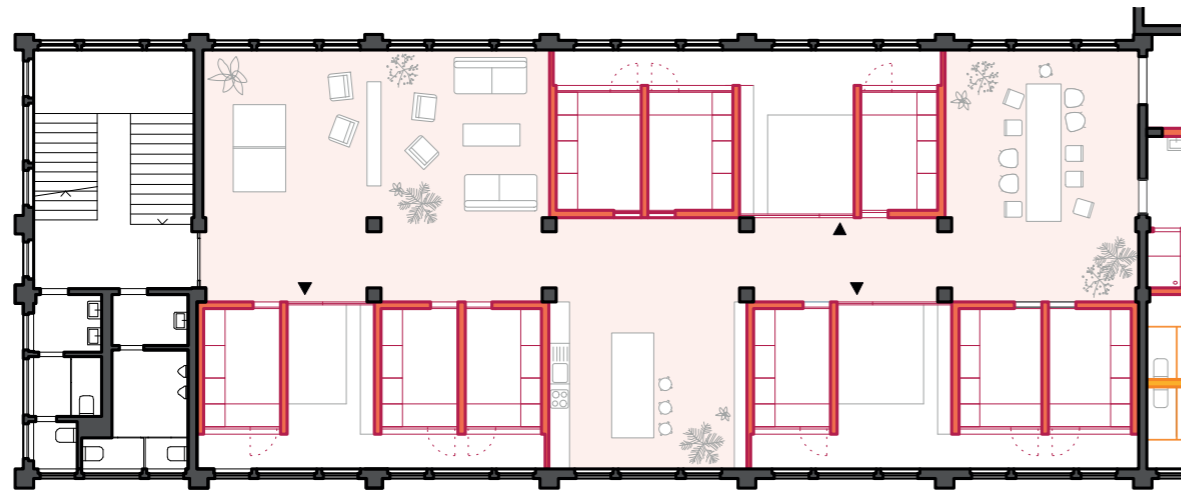

Detailausschnitt Wohnen

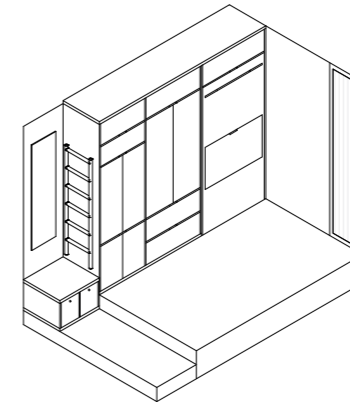

AUSGANGSFORM

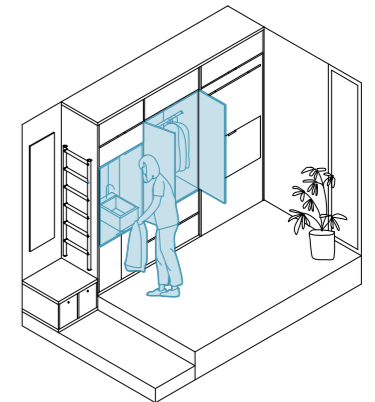

MORGENS
Nutzung Waschbecken & Schrank

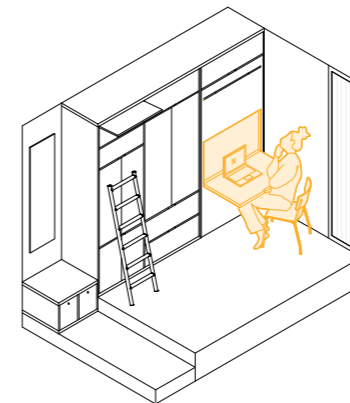

NACHMITTAGS
Schreibtisch für Hobbys

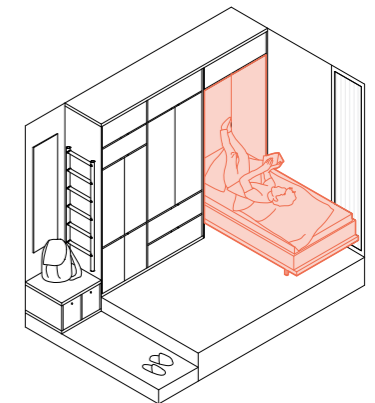

ABENDS | NACHTS
Bett zum Schlafen und Entspannen

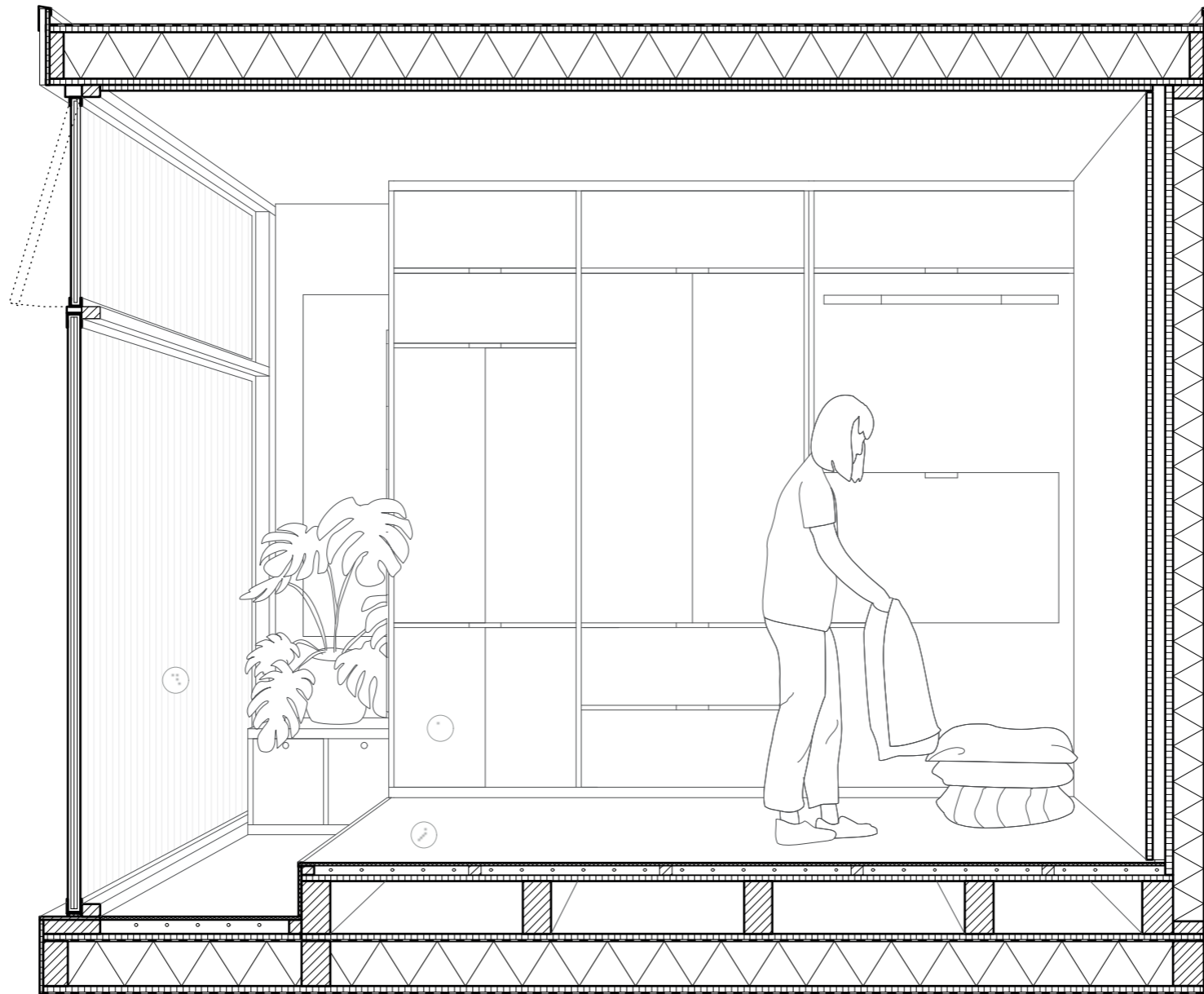

Detailschnitt Wohnmodul



X.CAMPUS
Baufornenlehre
Elisabeth Schmidt

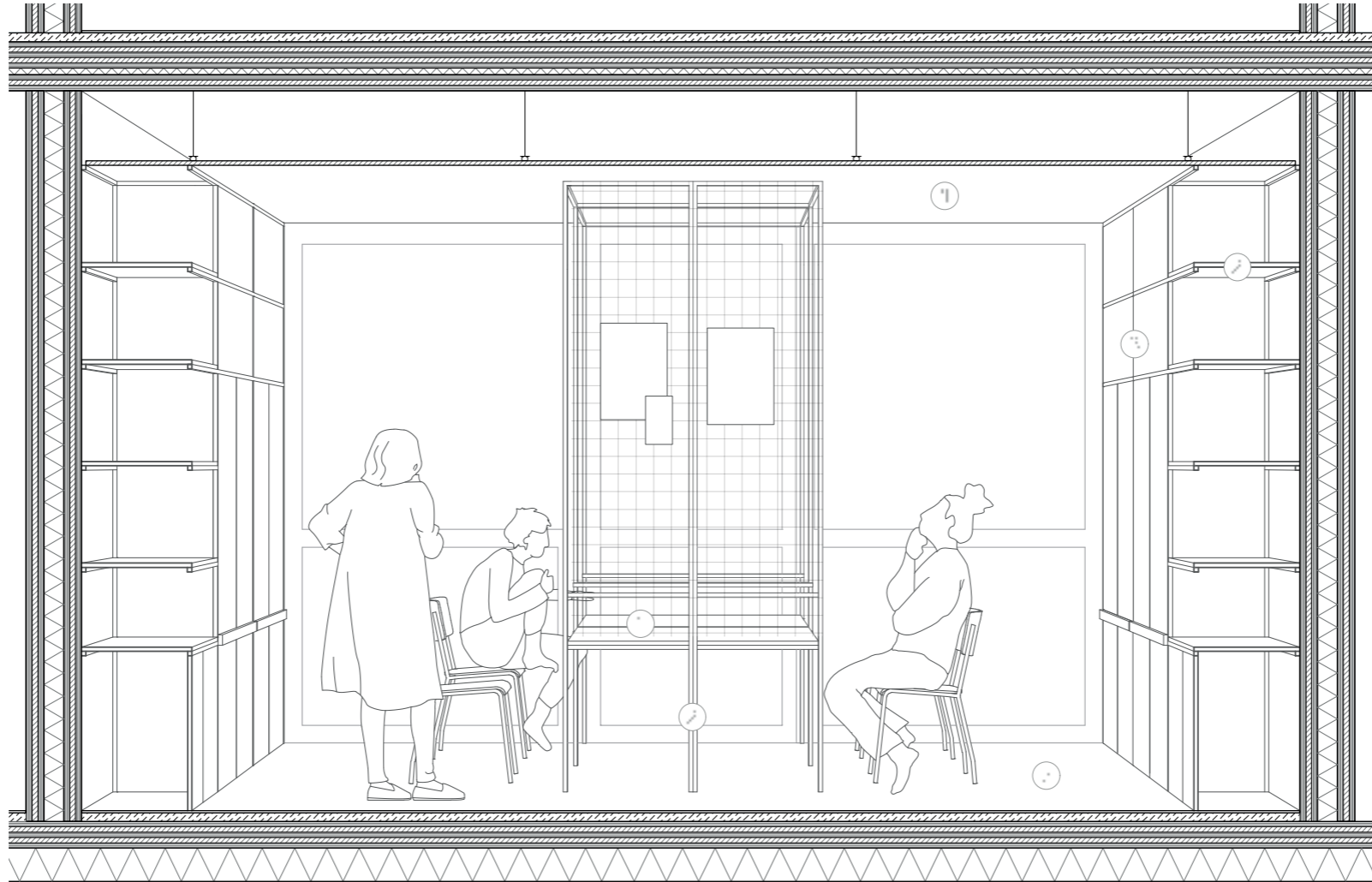

Detailschnitt Arbeitsraummodul

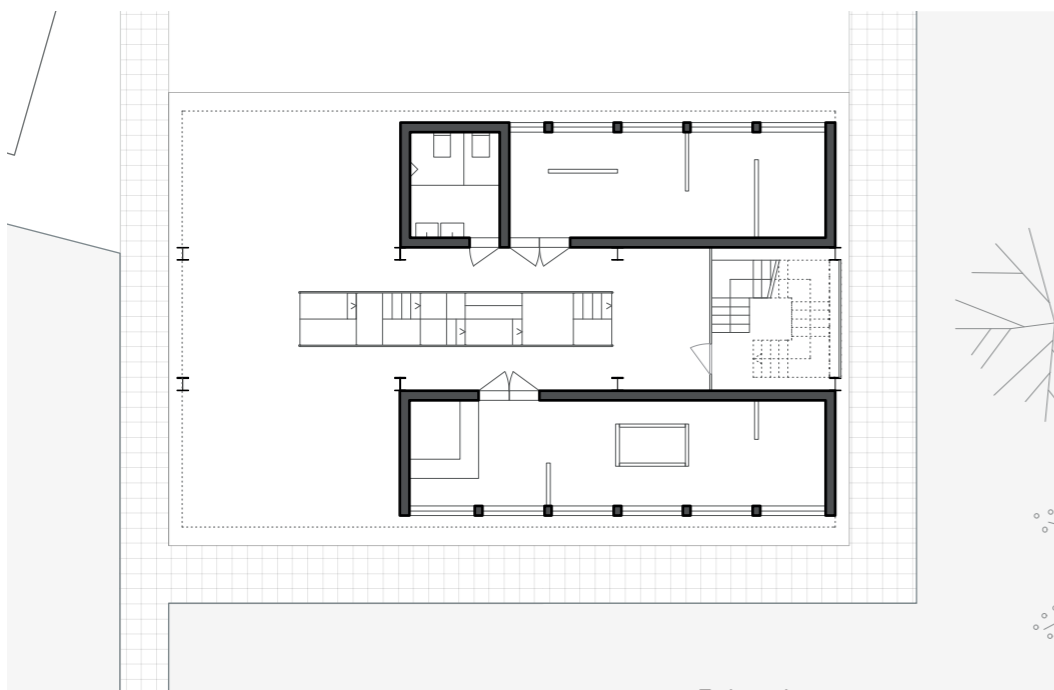

Erdgeschoss



1.Obergeschoss

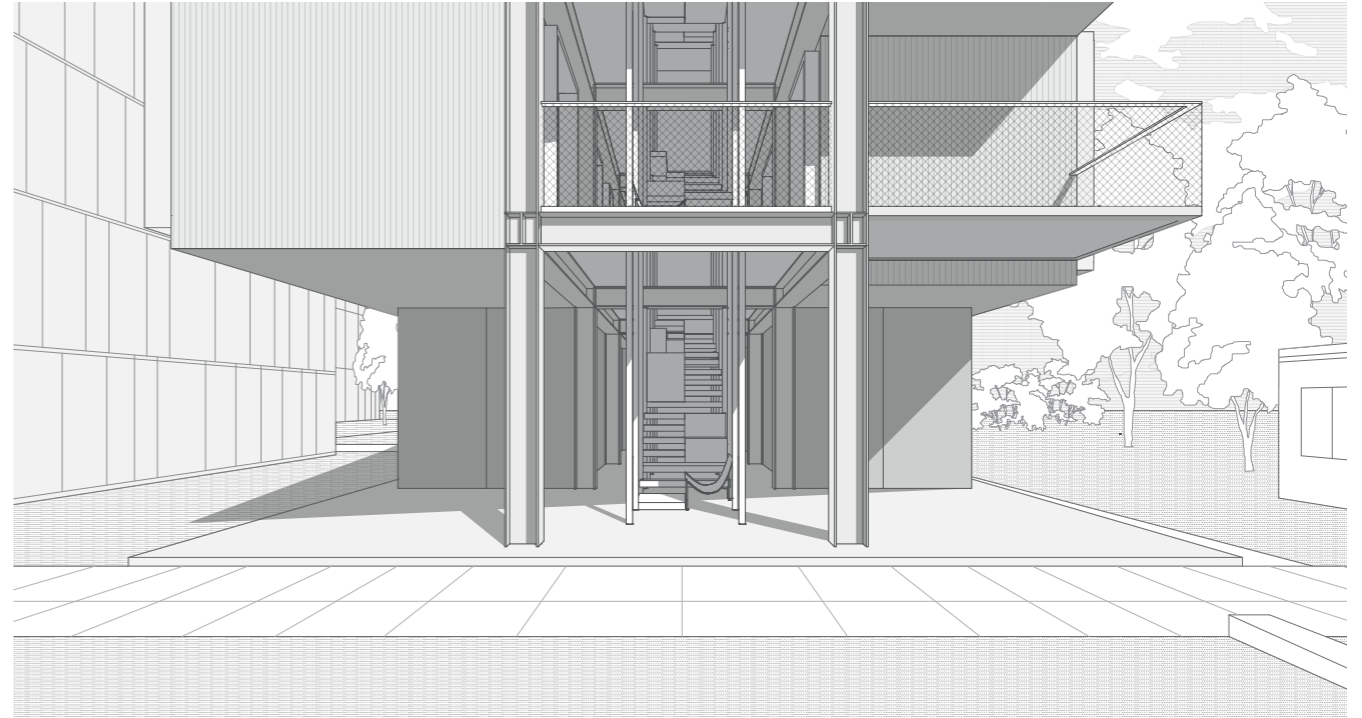



Grundriss detailliert



Erdgeschoss



Wohnmodul



Wohnmodul



Wohnmodul



X.CAMPUS
Bauformenlehre
Felix Alexander Roder

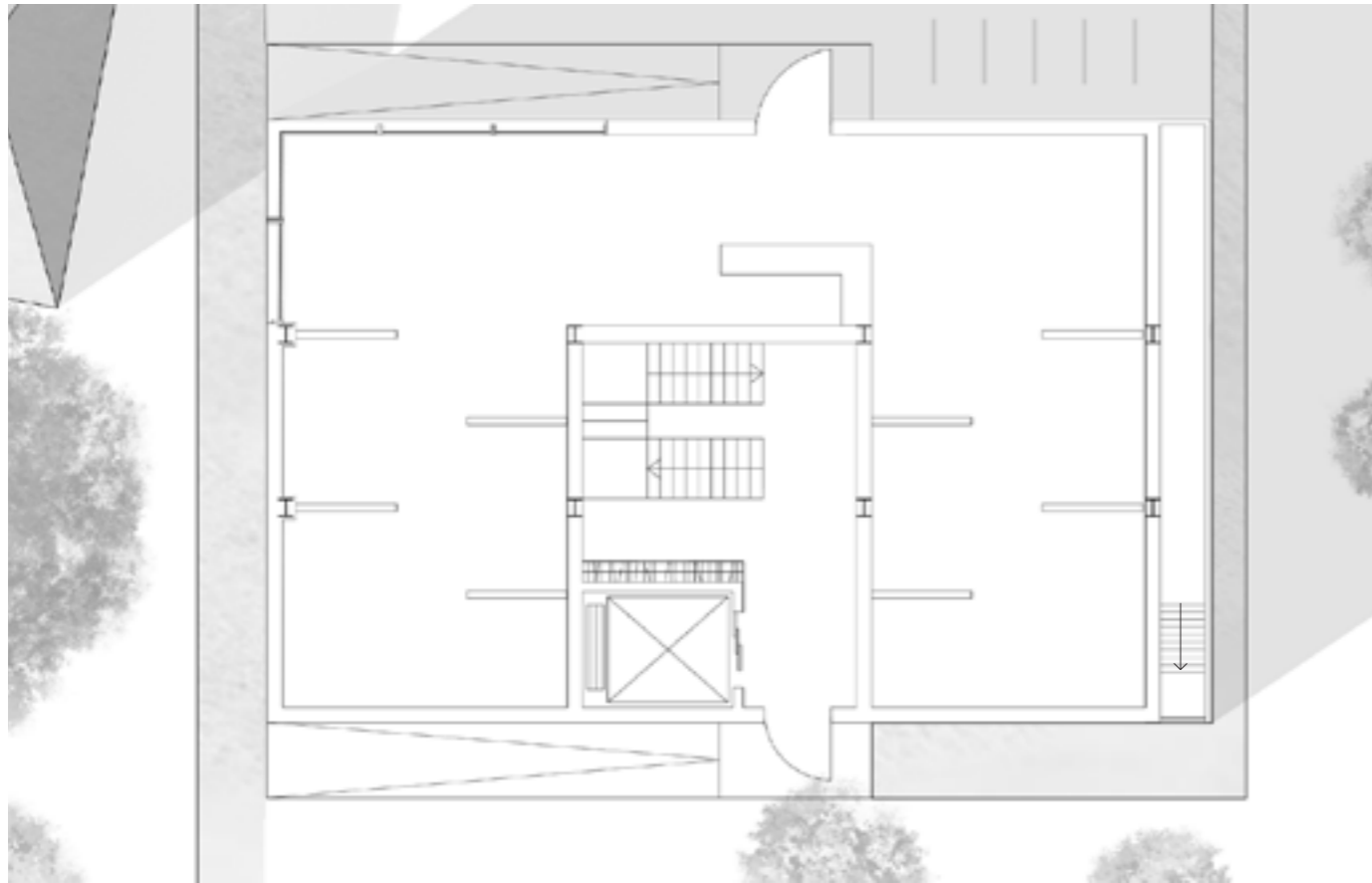

Erdgeschoss



1.Obergeschoss

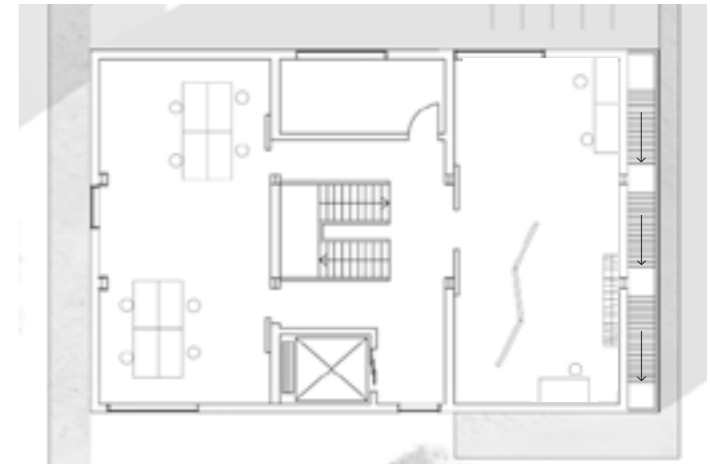

2.Obergeschoss



Schnitt

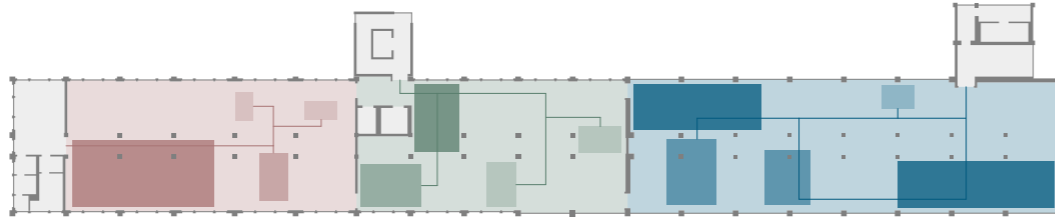

BEZIEHUNGEN

innenhof | marktplatz

individuelle wegebeziehungen
ermöglichen öffentliche marktplätze
und privatere innenhöfe

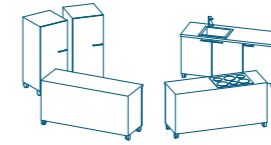

FRAGMENTE

anpassung | mobil

alle möbel und objekte schwimmen
frei im raum, sie werden als fragmente in
zeitlichen zyklen neu arrangiert

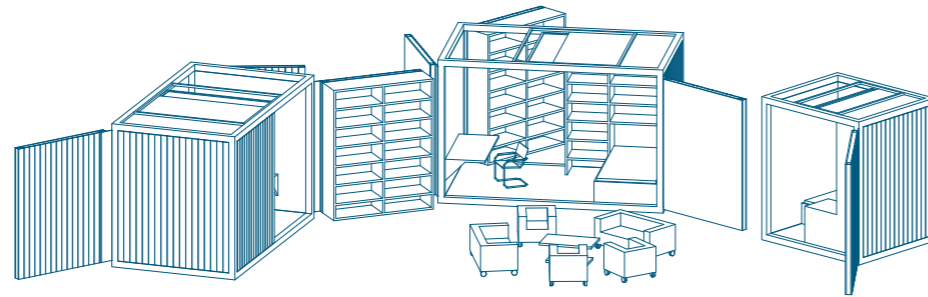

INNENHOF

öffnen | verschmelzen | wohnen

geöffnete private kapseln bringen
ihre eigenschaften in den benachbarten öffentlichen
raum und prägen dessen qualitäten

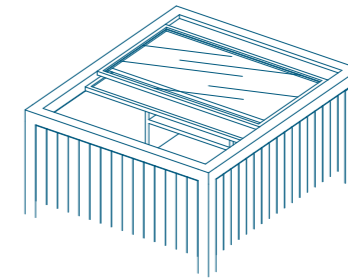

ÖFFNUNG

belüften | belichten | abschirmen

glas und stoff dienen zur akustischen
öffnung, belichtung und belüftung nahezu
hermetisch verschlossener räume



1.Obergeschoss

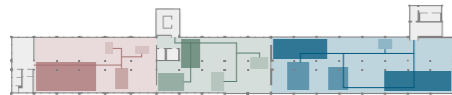

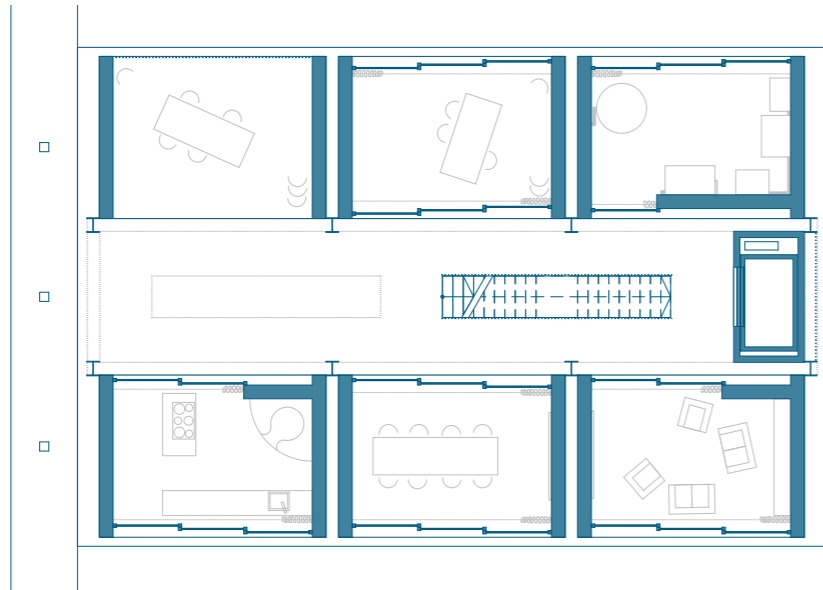

Erdgeschoss

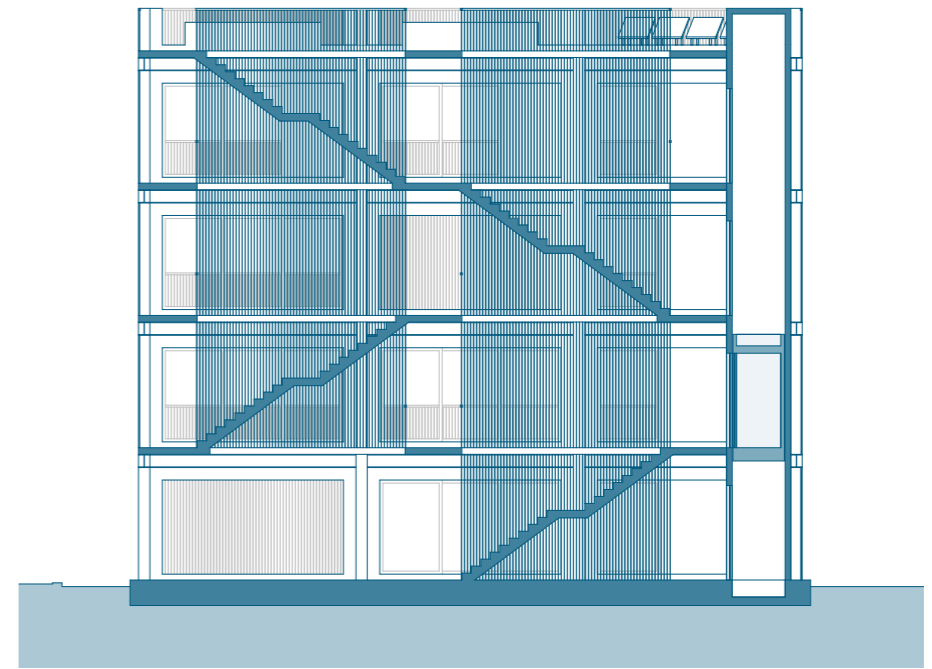

Schnitt

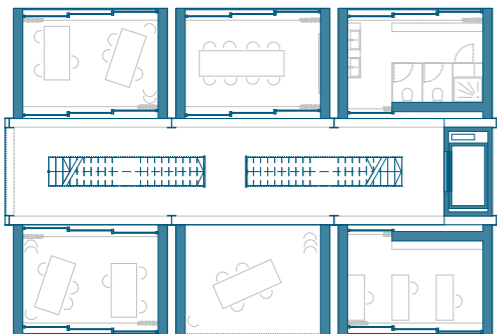

1.Obergeschoss

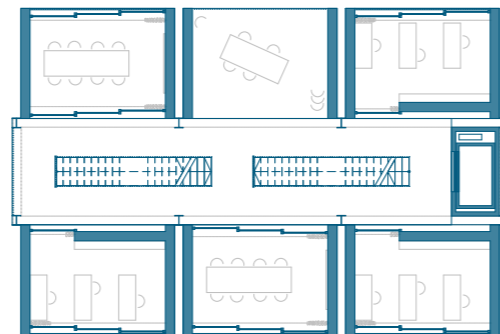

2.Obergeschoss

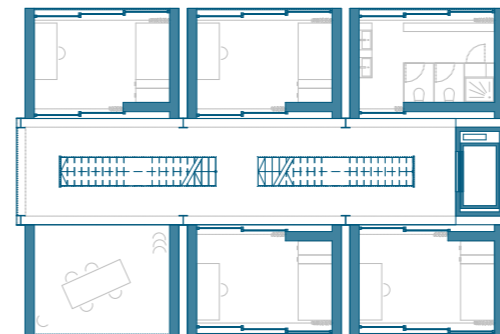

3.Obergeschoss

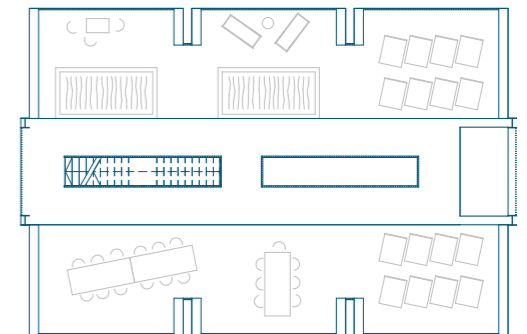

Dachgeschoss



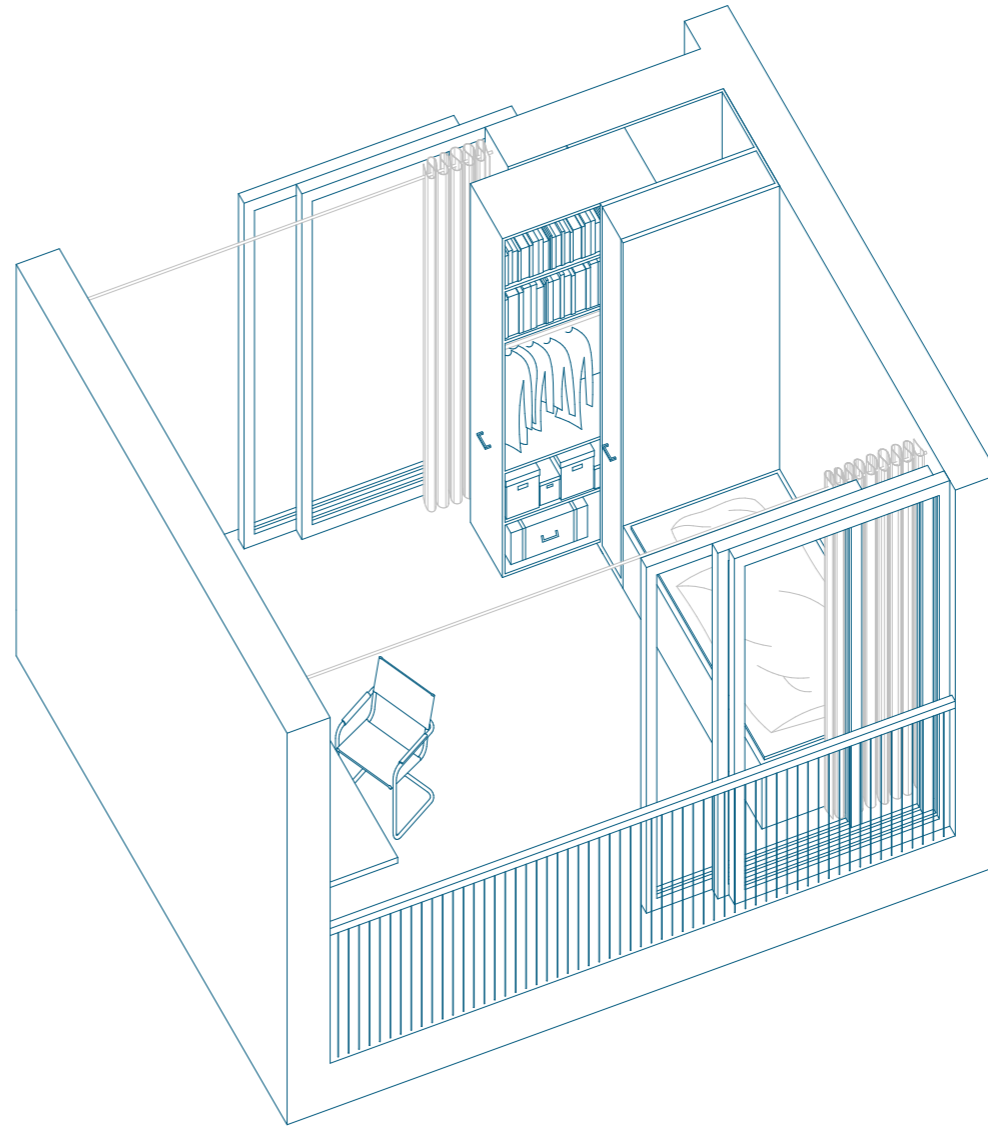
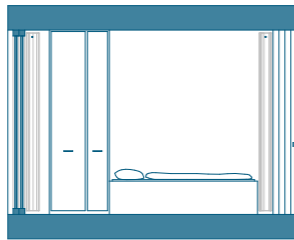
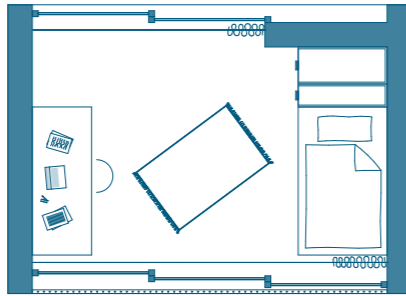
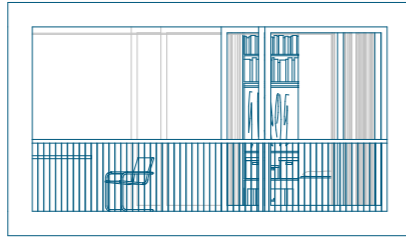

Wohncontainer

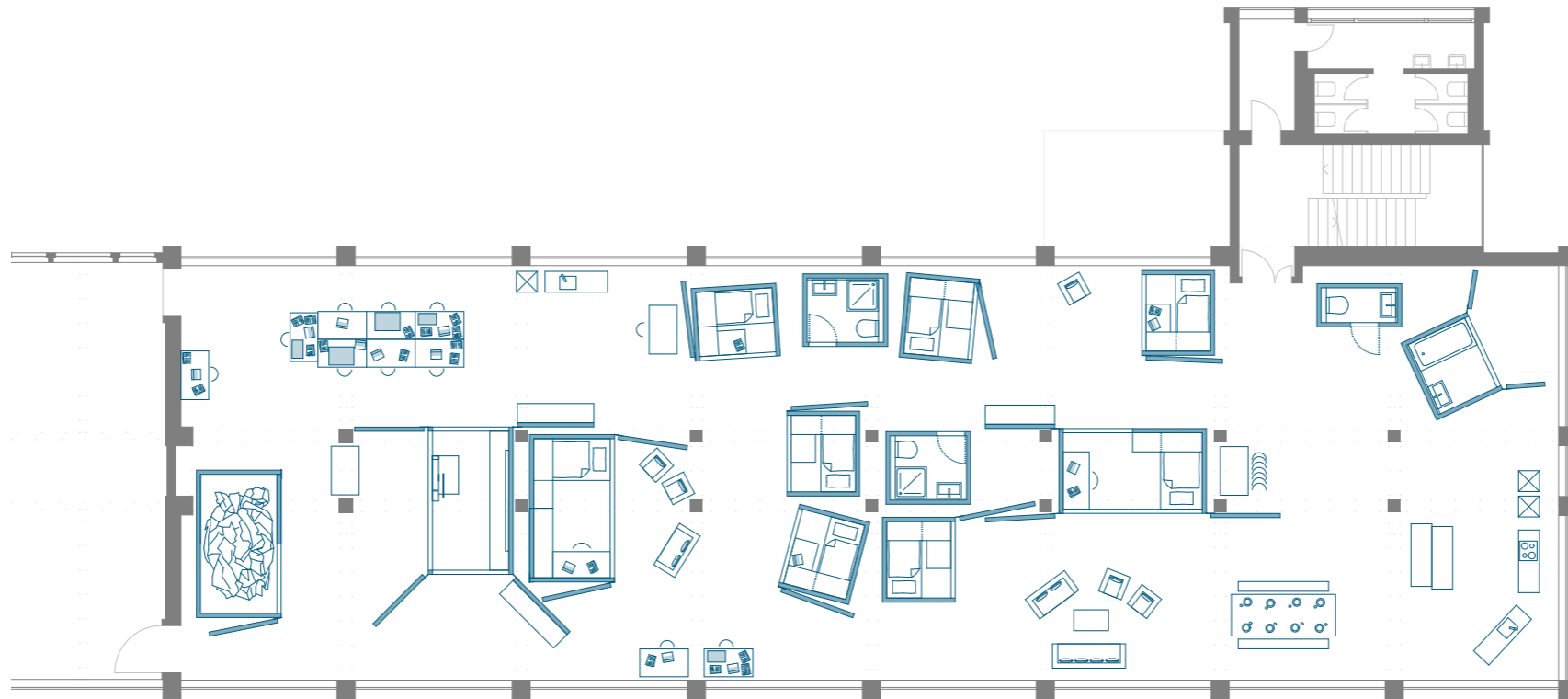

Wohngemeinschaft

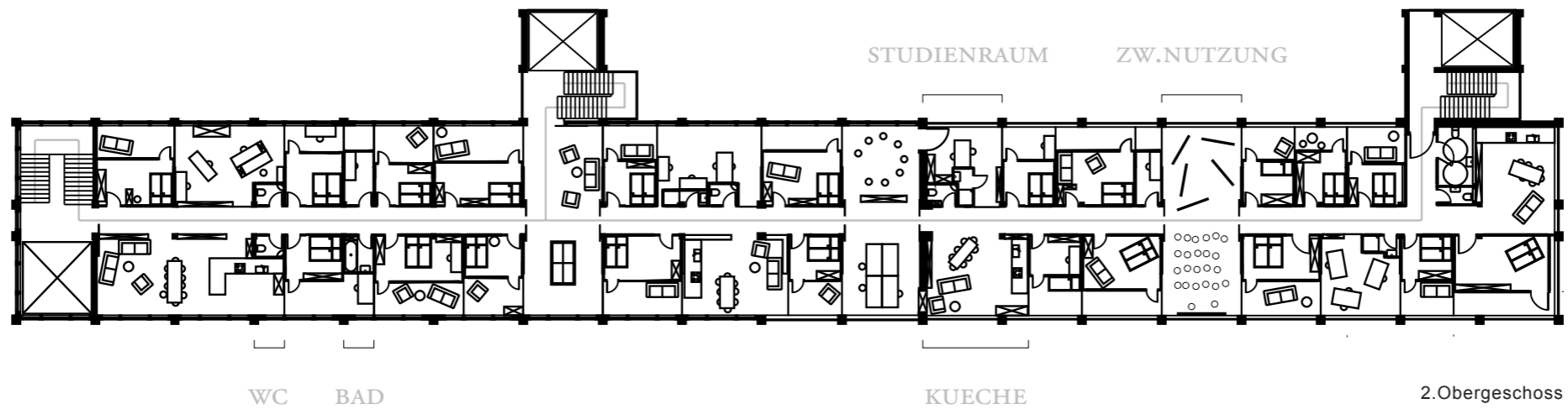
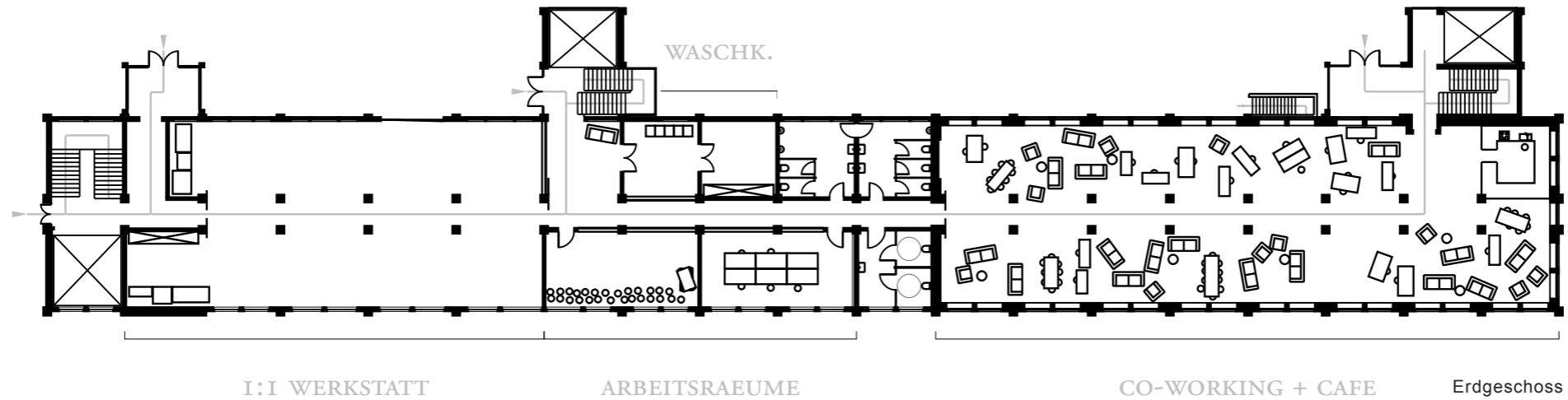

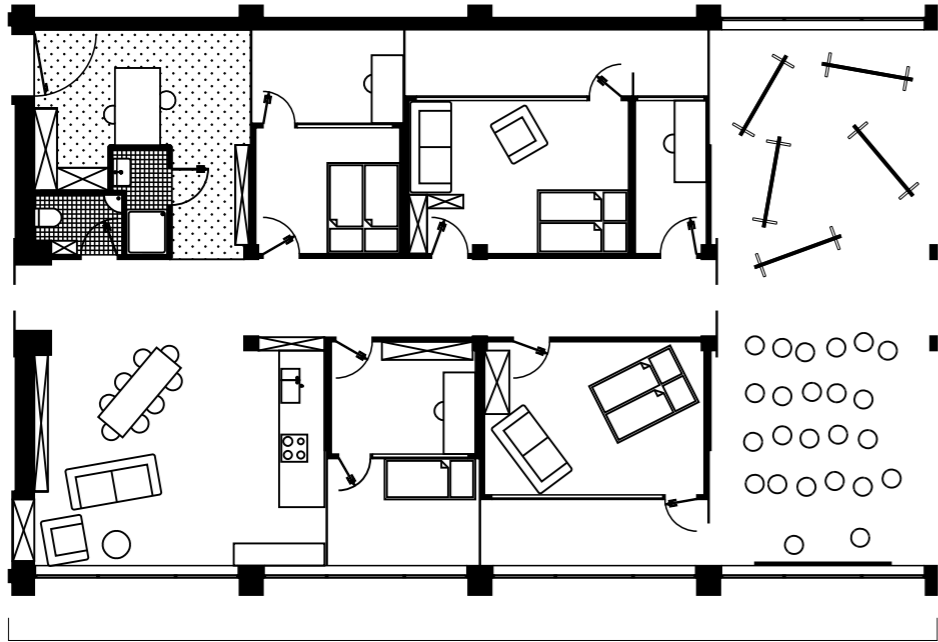

Grundriss Wohnen

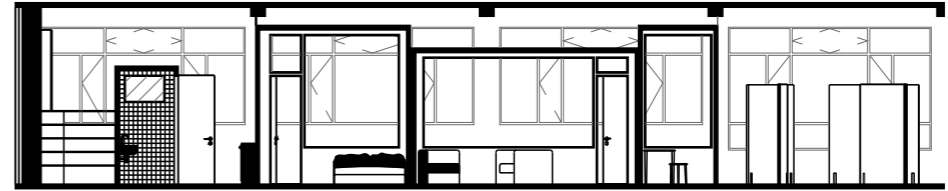

Schnitt Wohnen 1

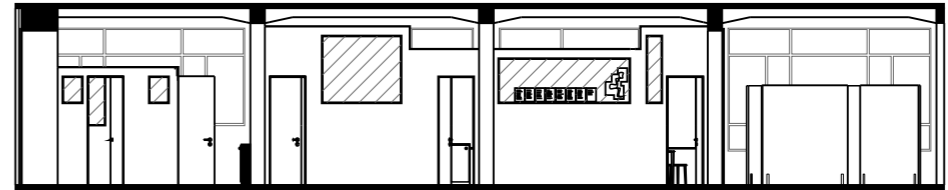

Schnitt Wohnen 2

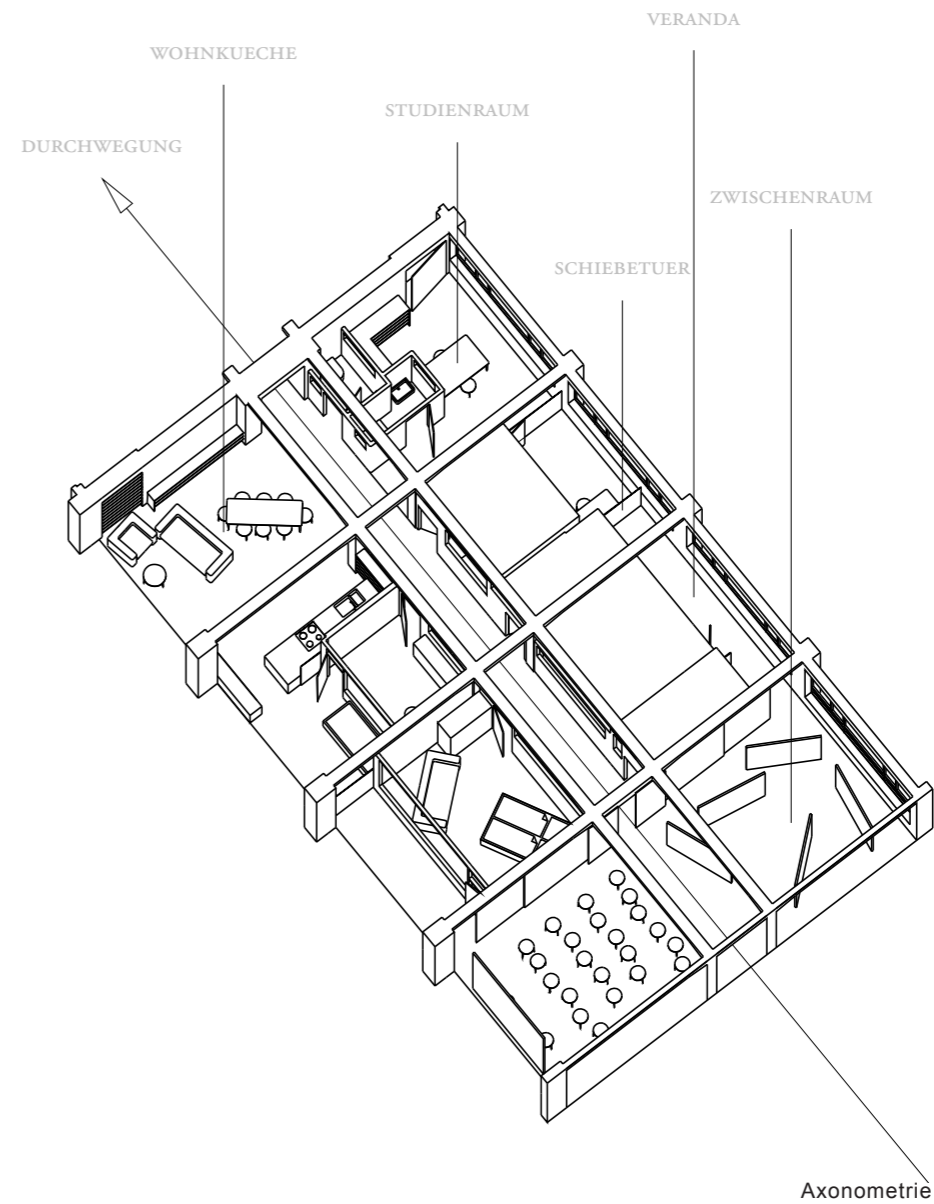



X.CAMPUS
Bauformenlehre
Felix Kofler

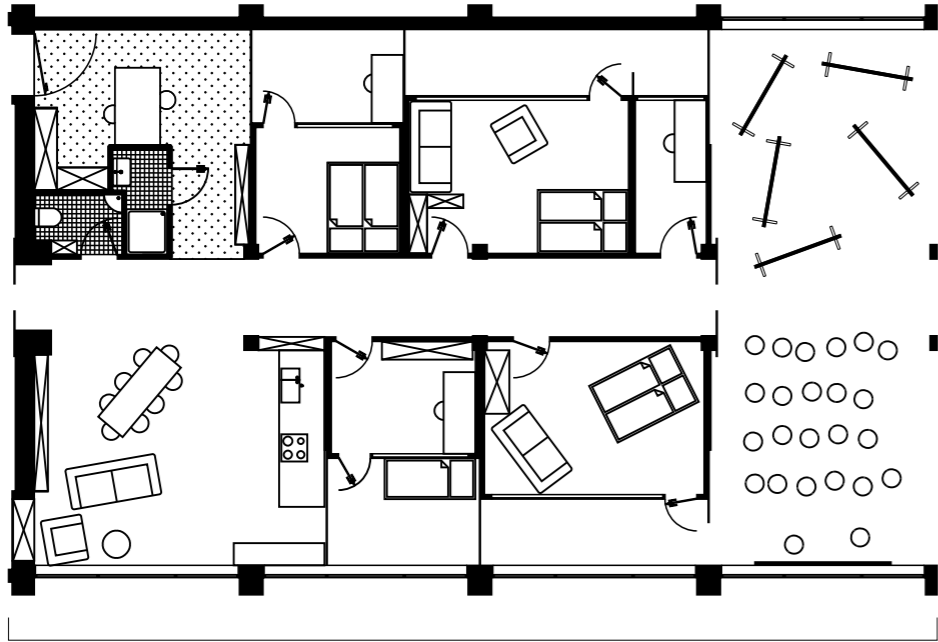

Grundriss Wohnen

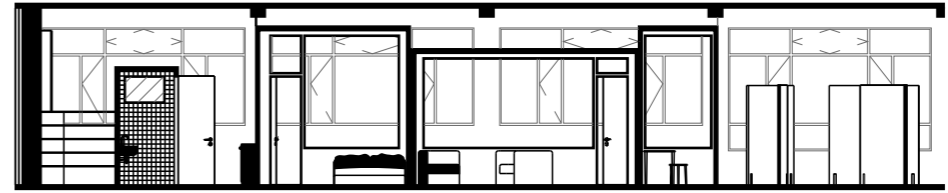

Schnitt Wohnen 1

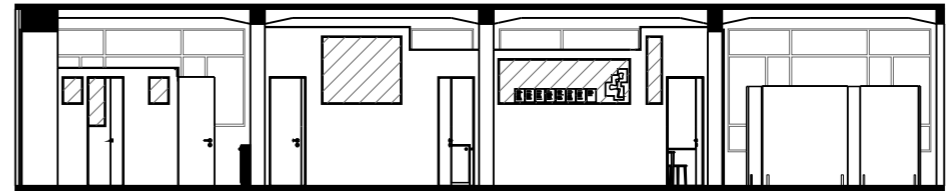

Schnitt Wohnen 2

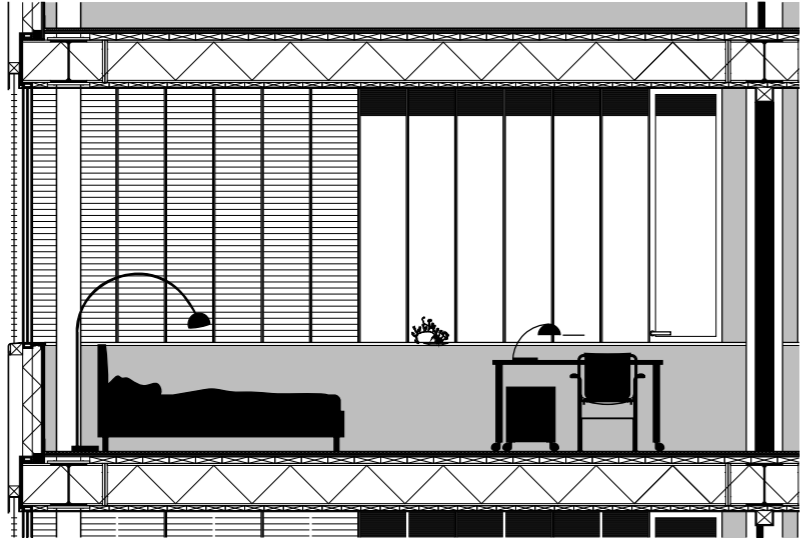

Schnitt Zimmer

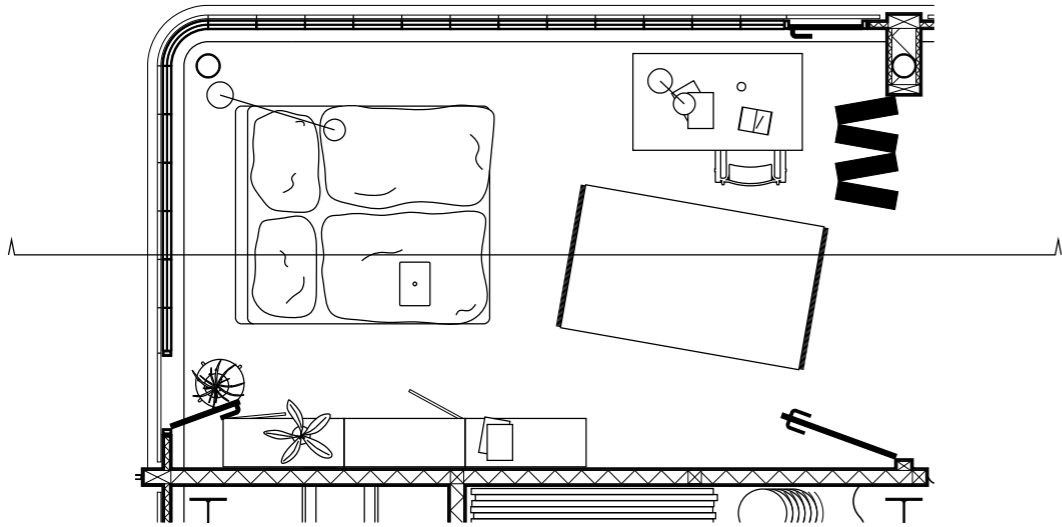

Grundriss Zimmer

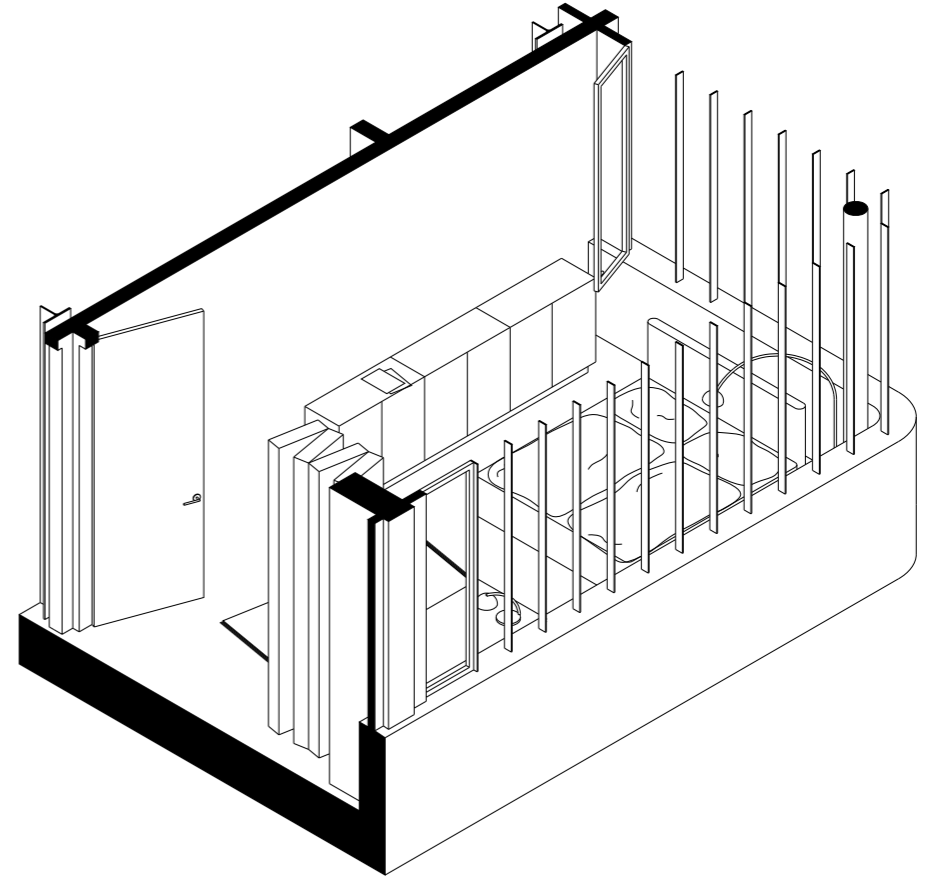

Axonometrie



Atelier/Studio



Eigenes Zimmer



Musikbox



Diskussionsraum



Wintergarten



Küche



Fragmentiertes Wohnen

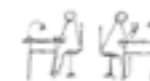

Bibliothek

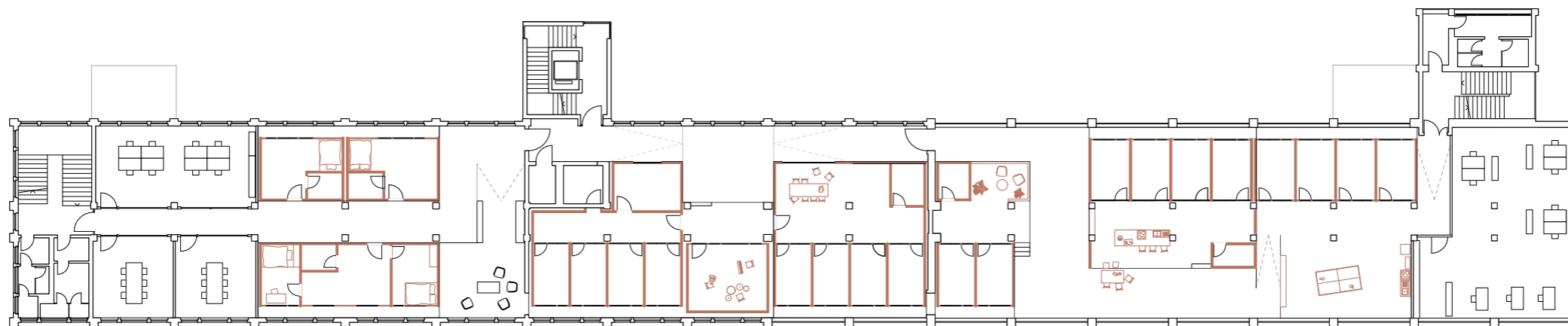

1.Obergeschoss

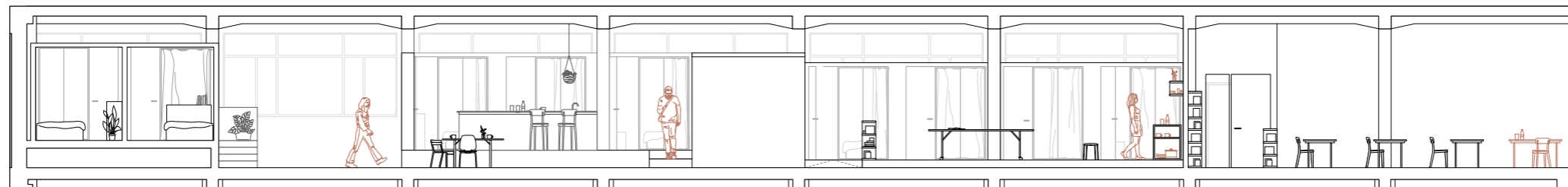

Schnitt 1.Obergeschoss

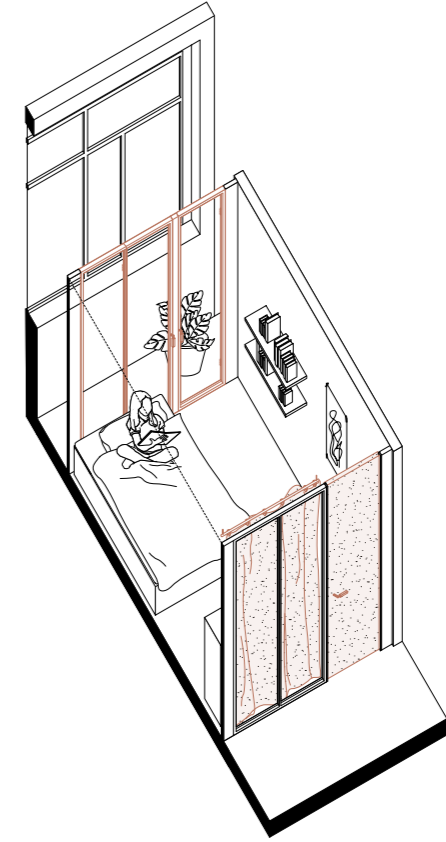
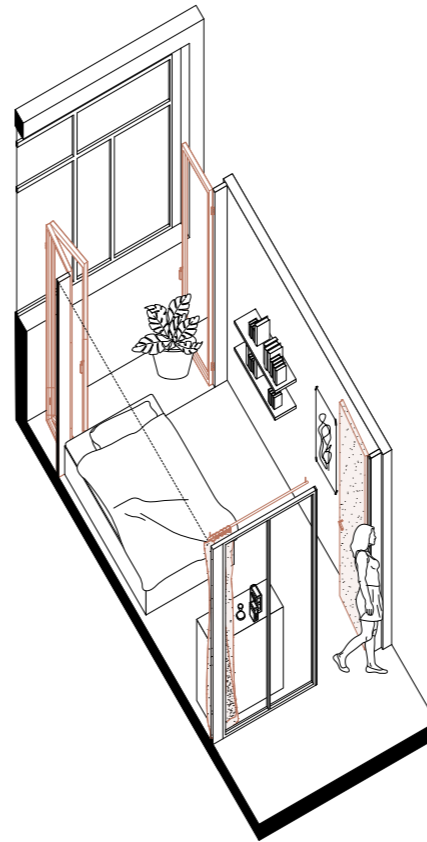

Isometrie Capsule

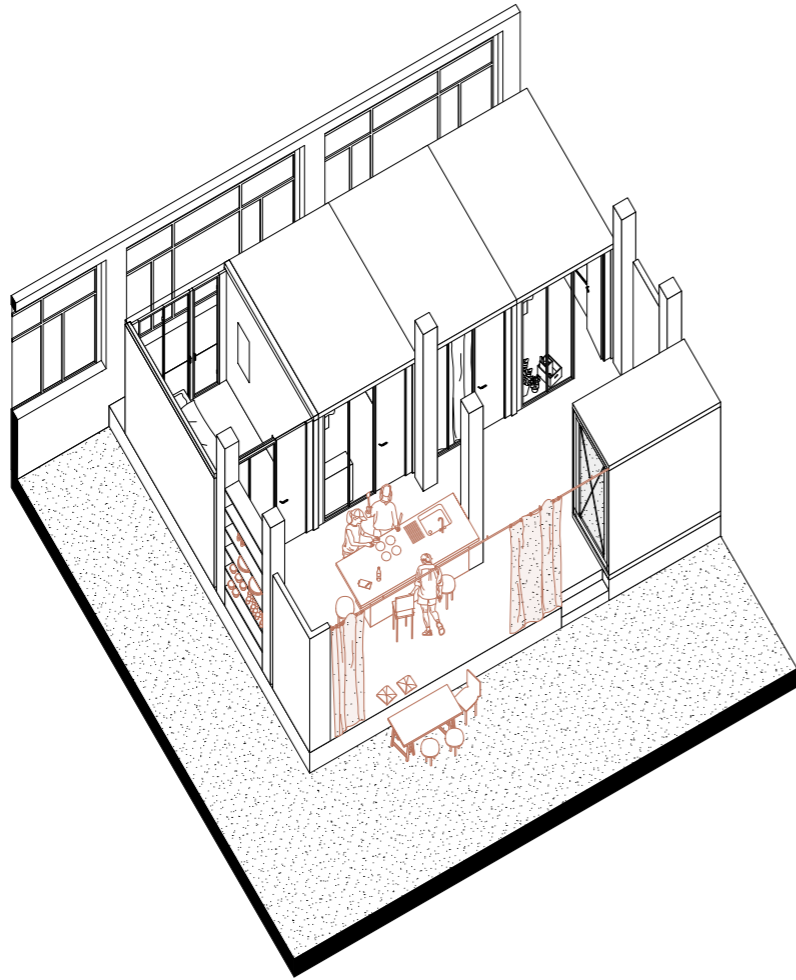

Isometrie Küche

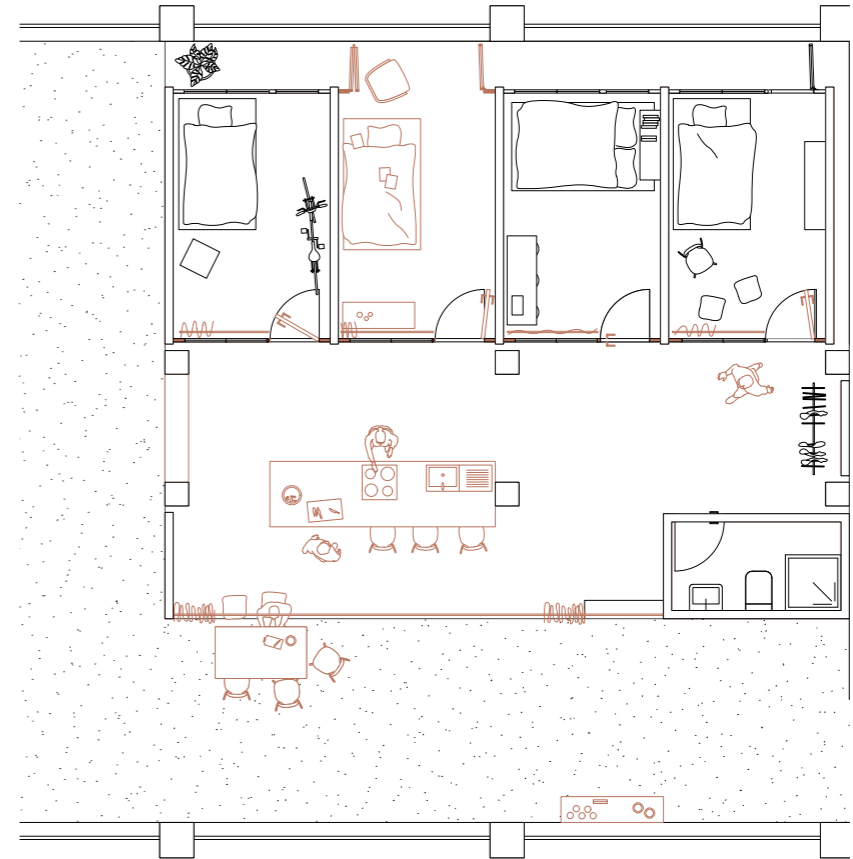

Grundriss

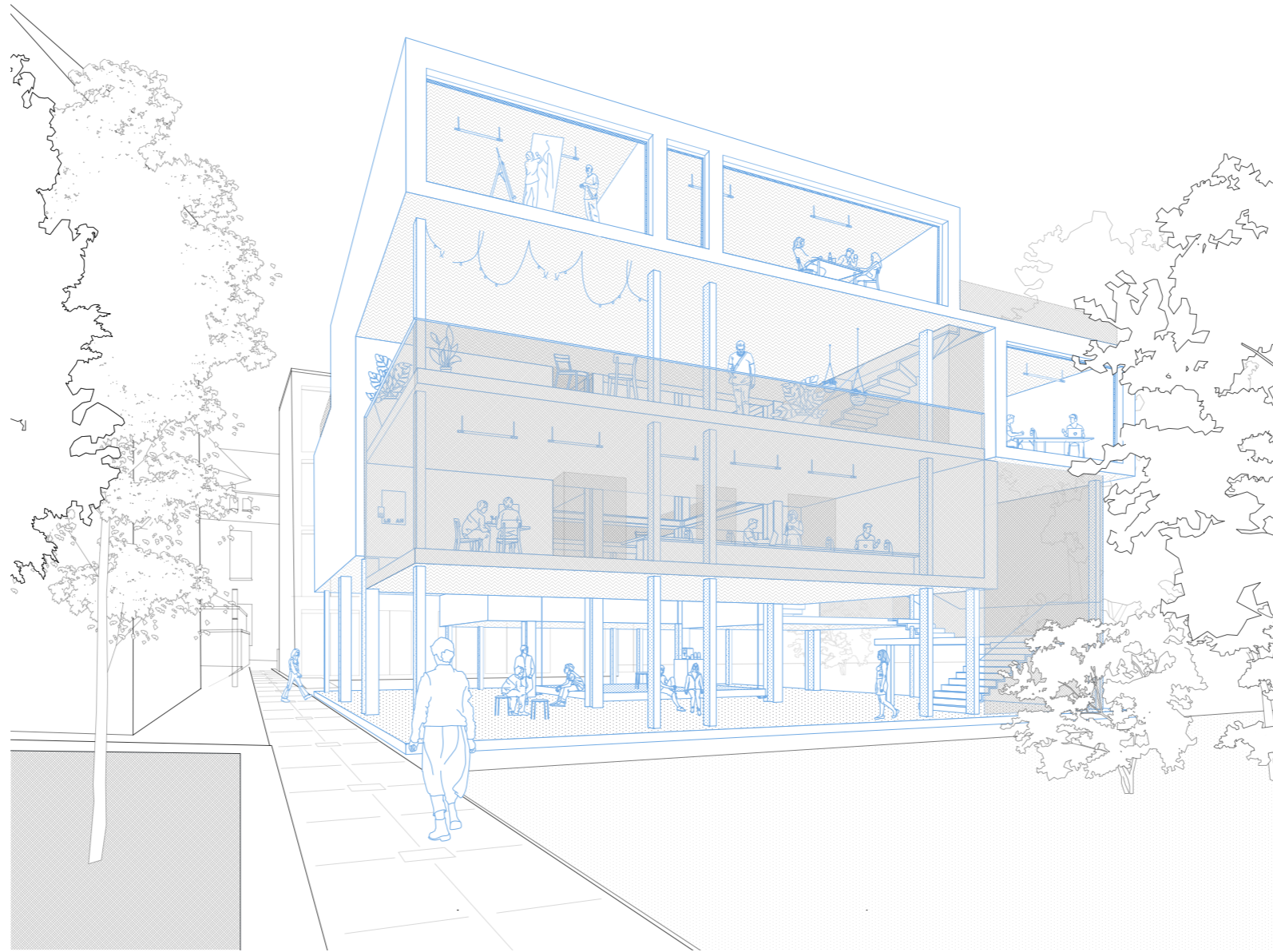

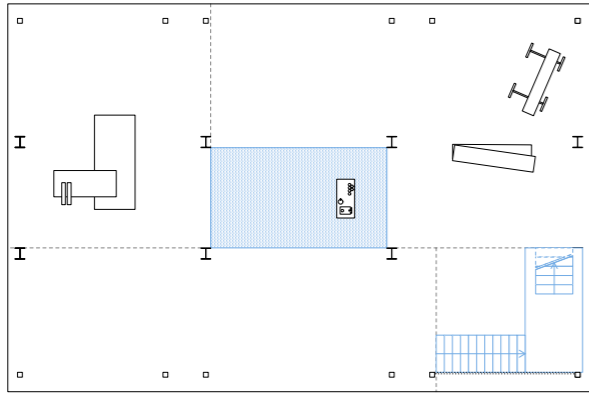

Erdgeschoss

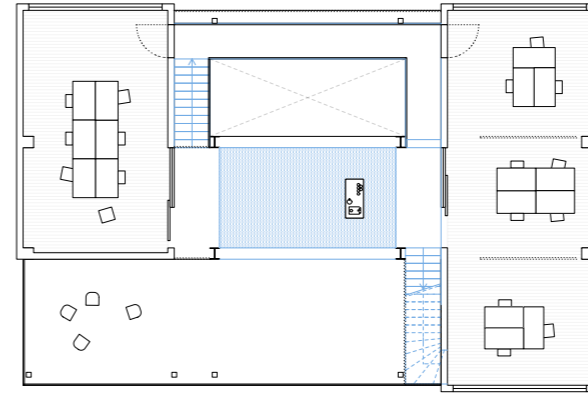
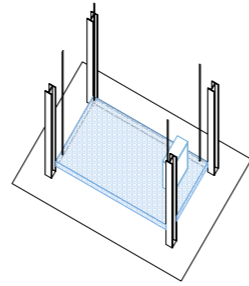

2.Obergeschoss

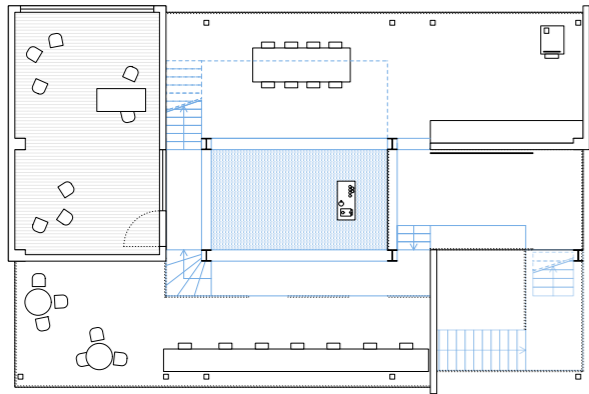
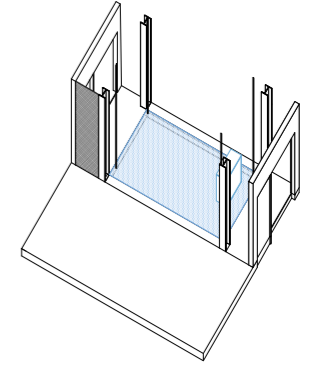

1.Obergeschoss

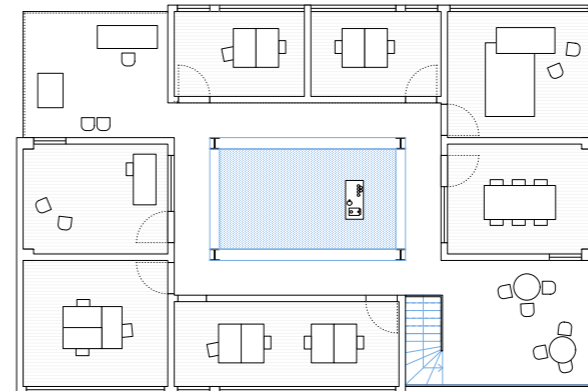
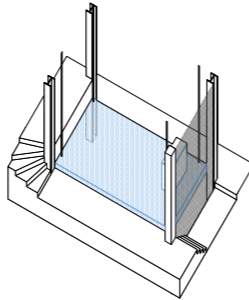

3.Obergeschoss

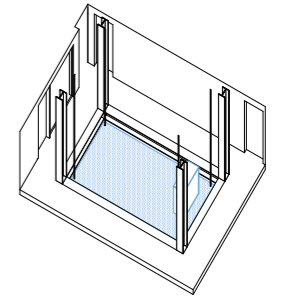

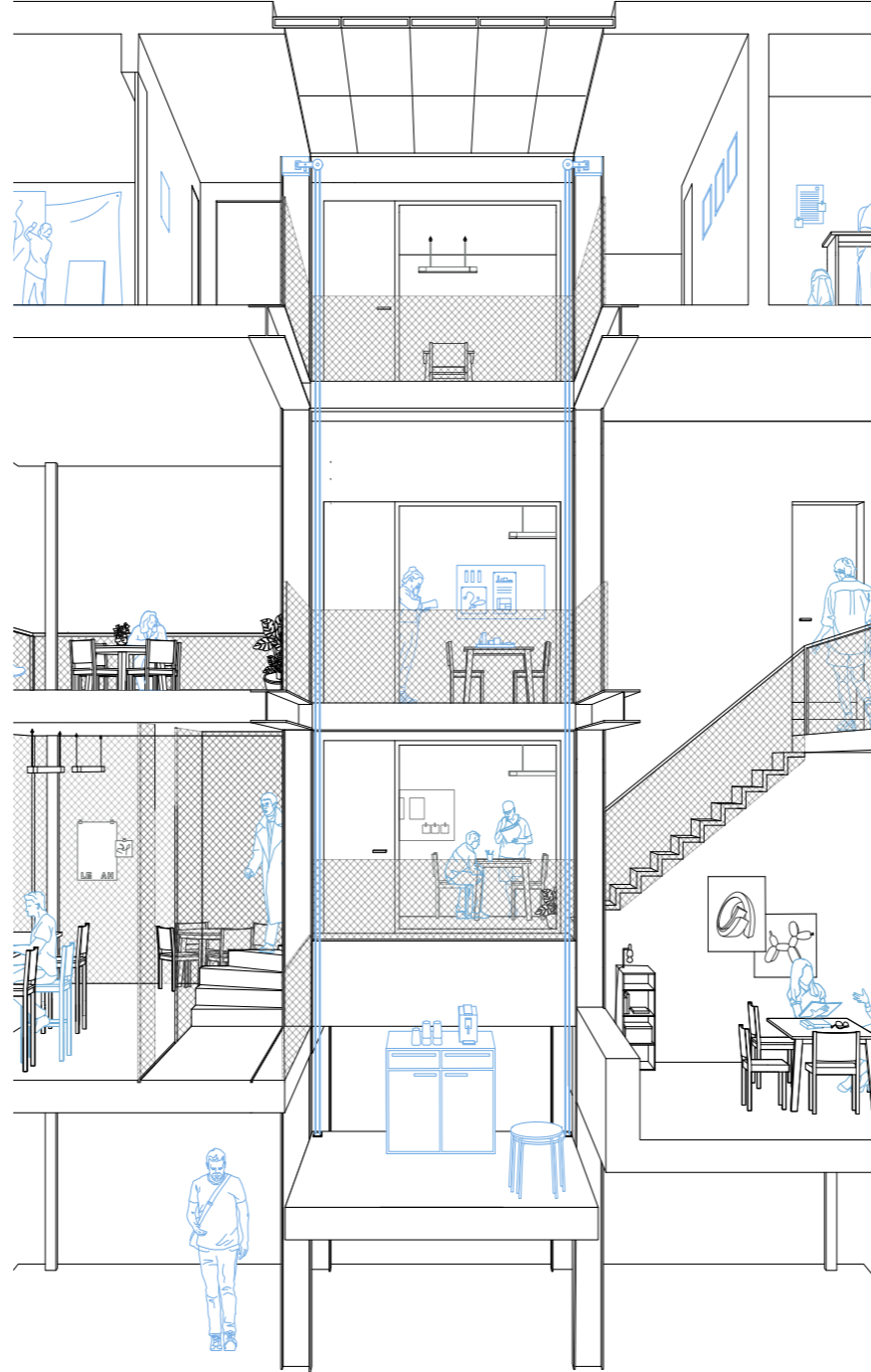

Schnittperspektive

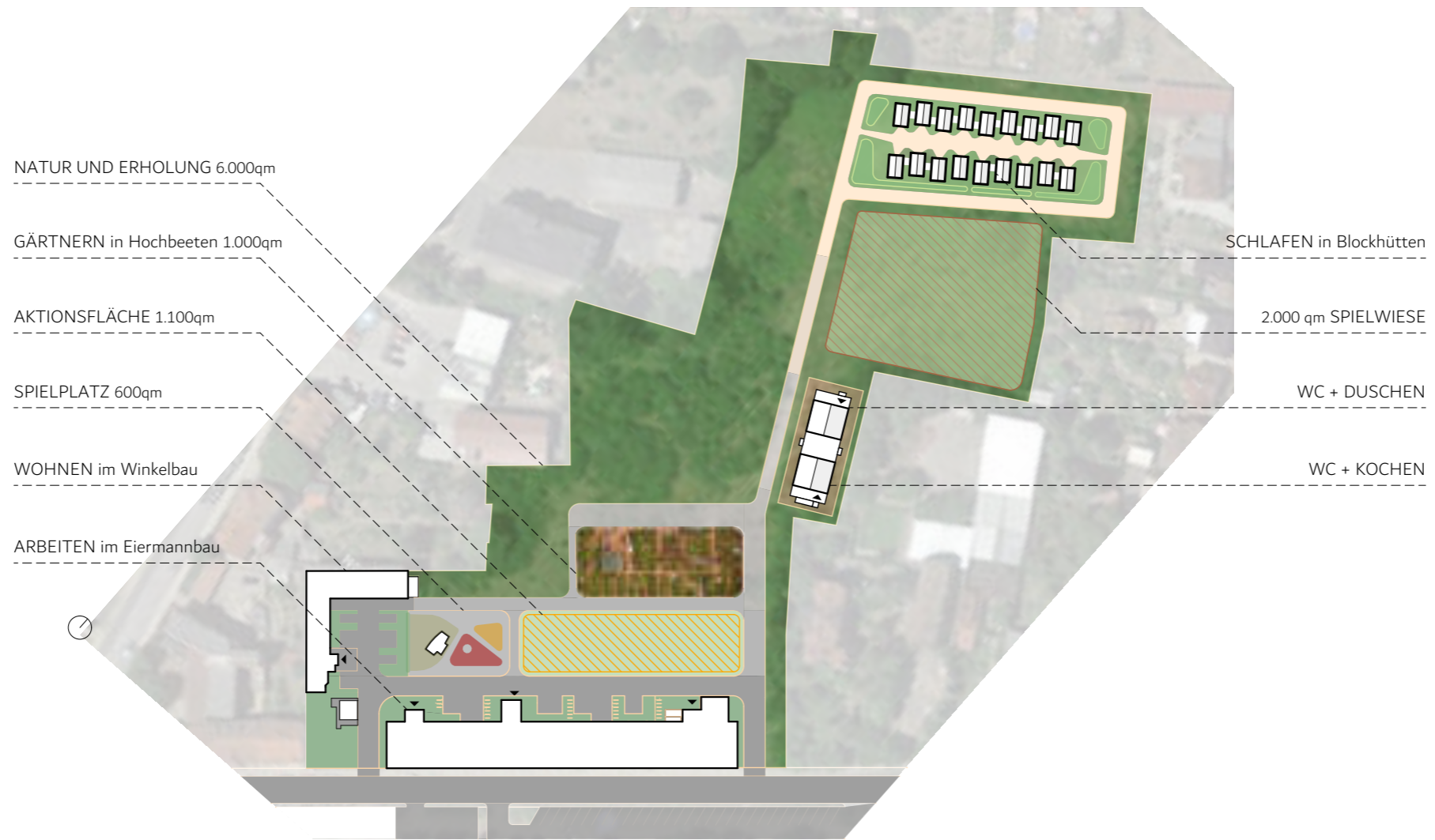

Lageplan

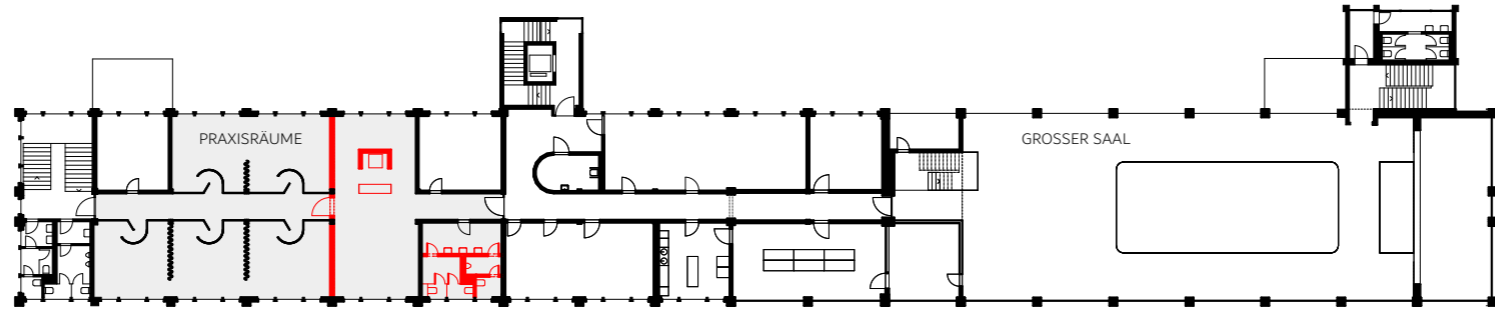

1.Obergeschoss

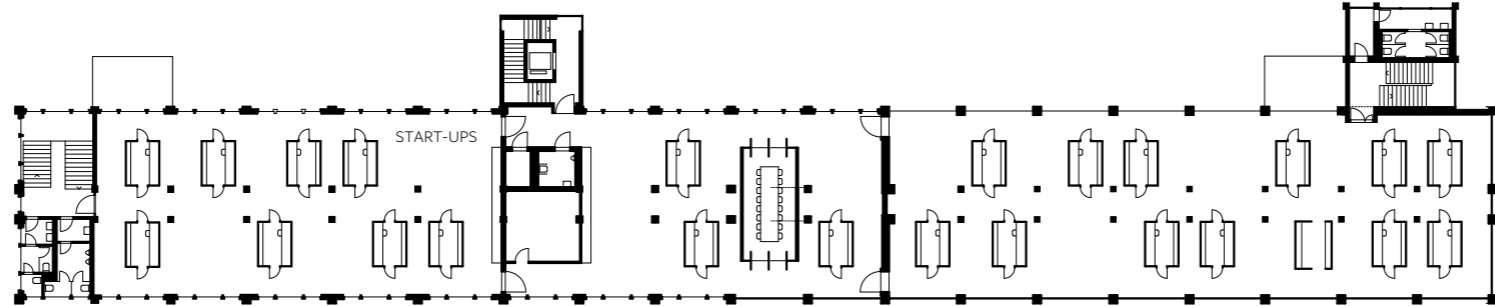

2.Obergeschoss

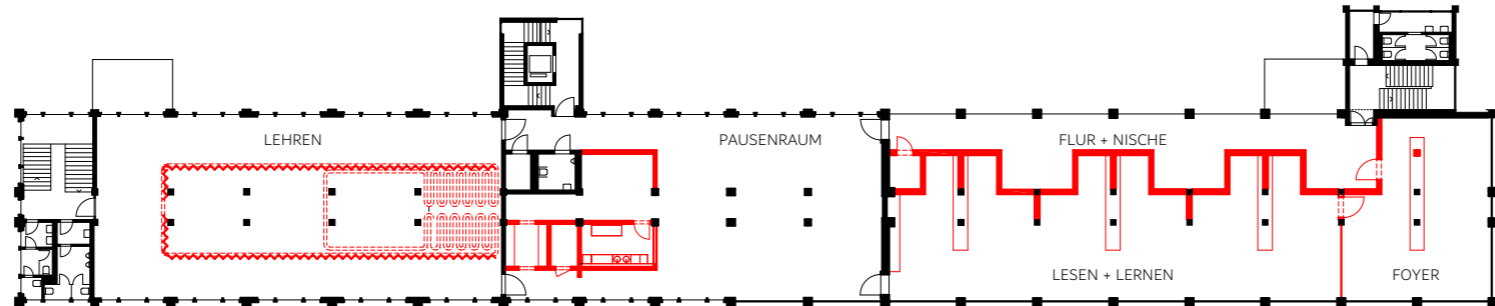

3.Obergeschoss



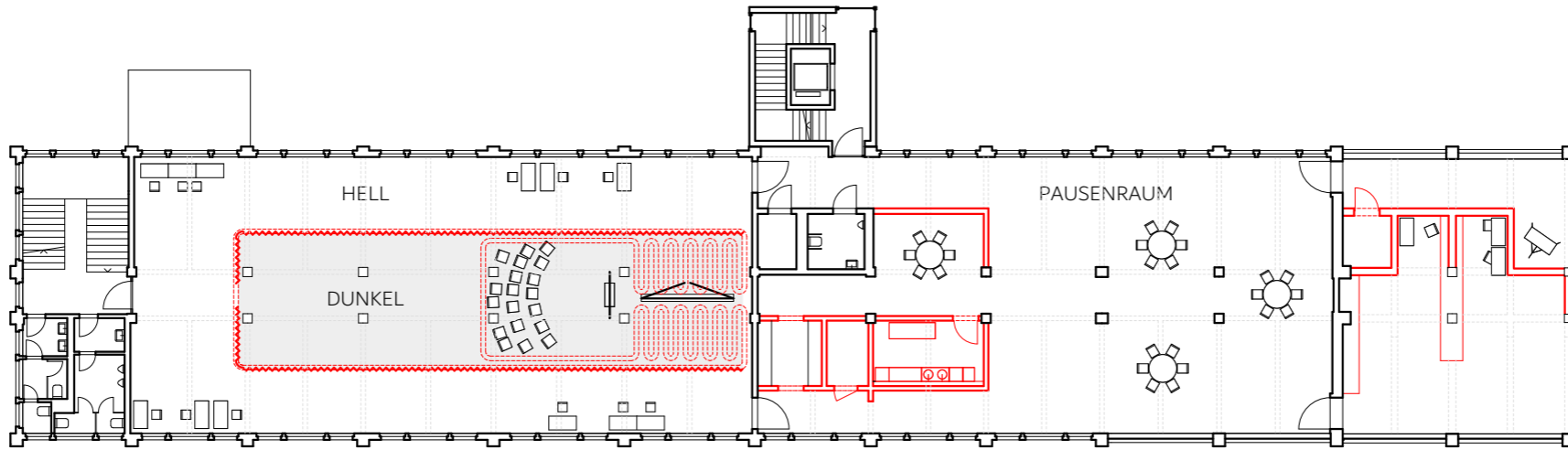

Grundrissvariante 1

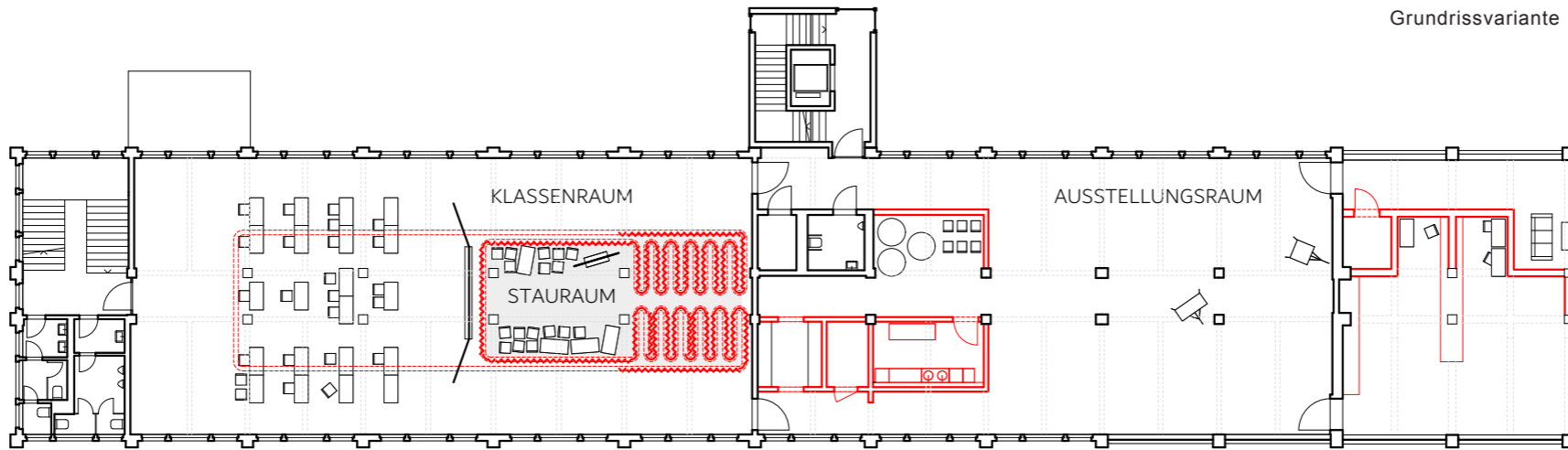

Grundrissvariante 2

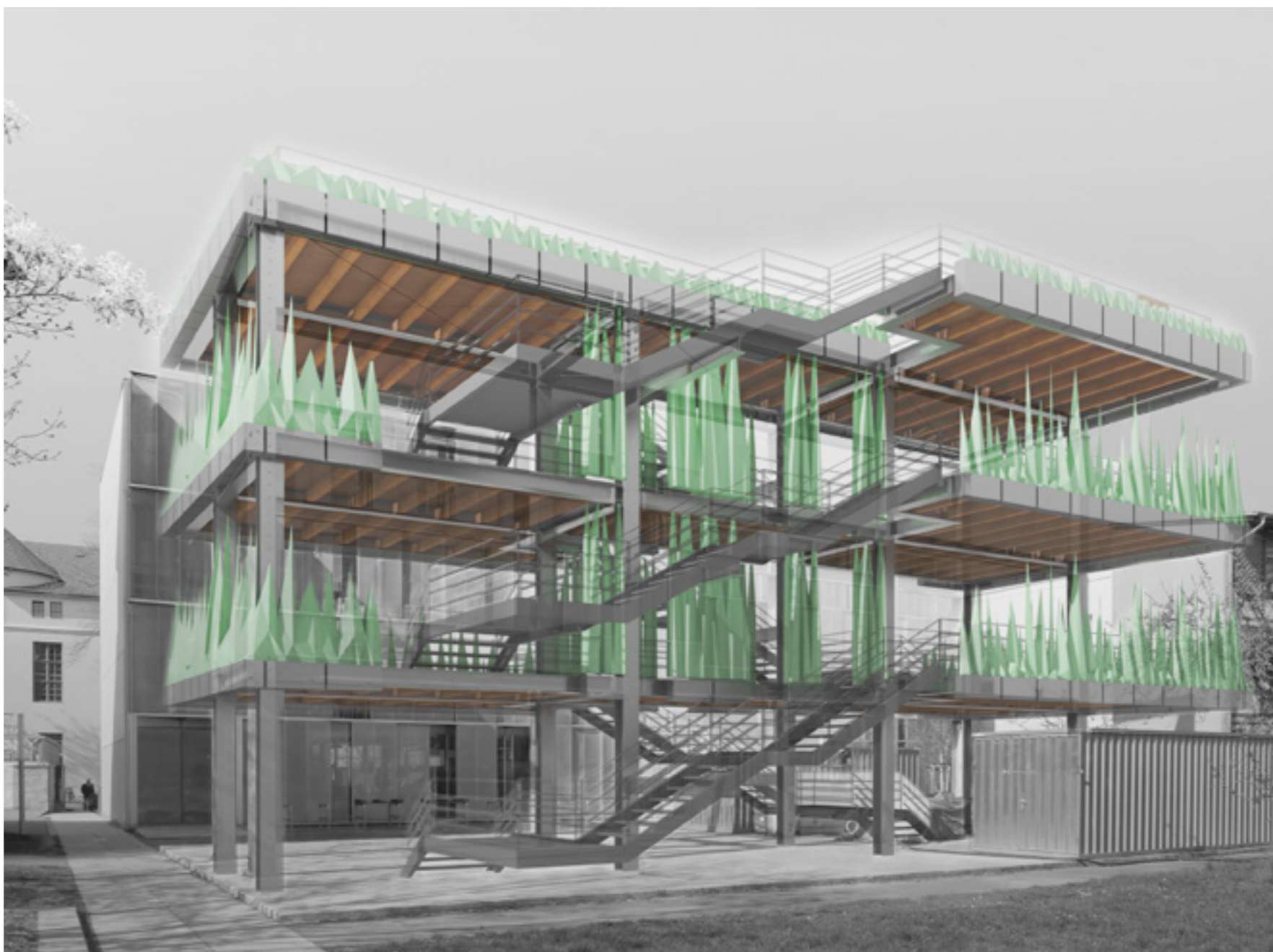

X.CAMPUS
Bauformenlehre
Tom Behammer

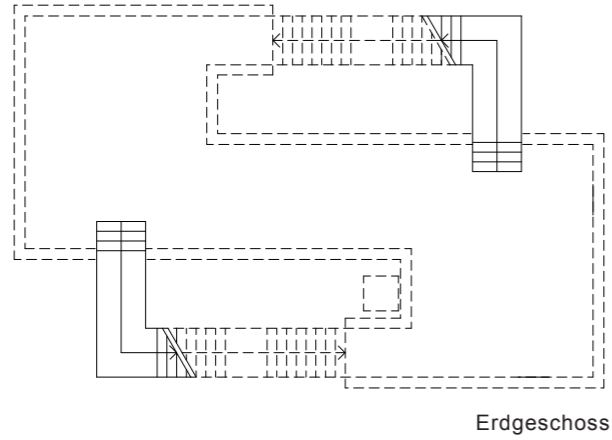

Erdgeschoss

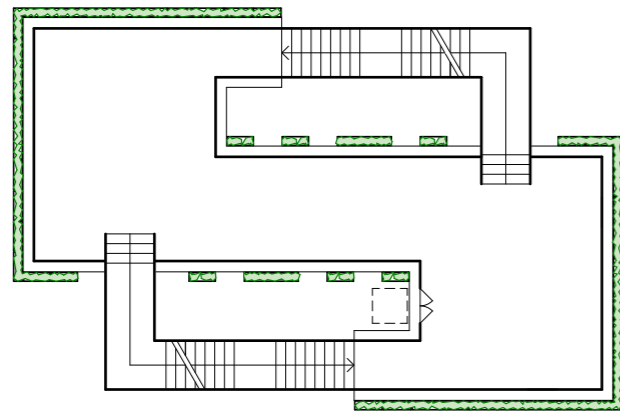

1.+2.Obergeschoss

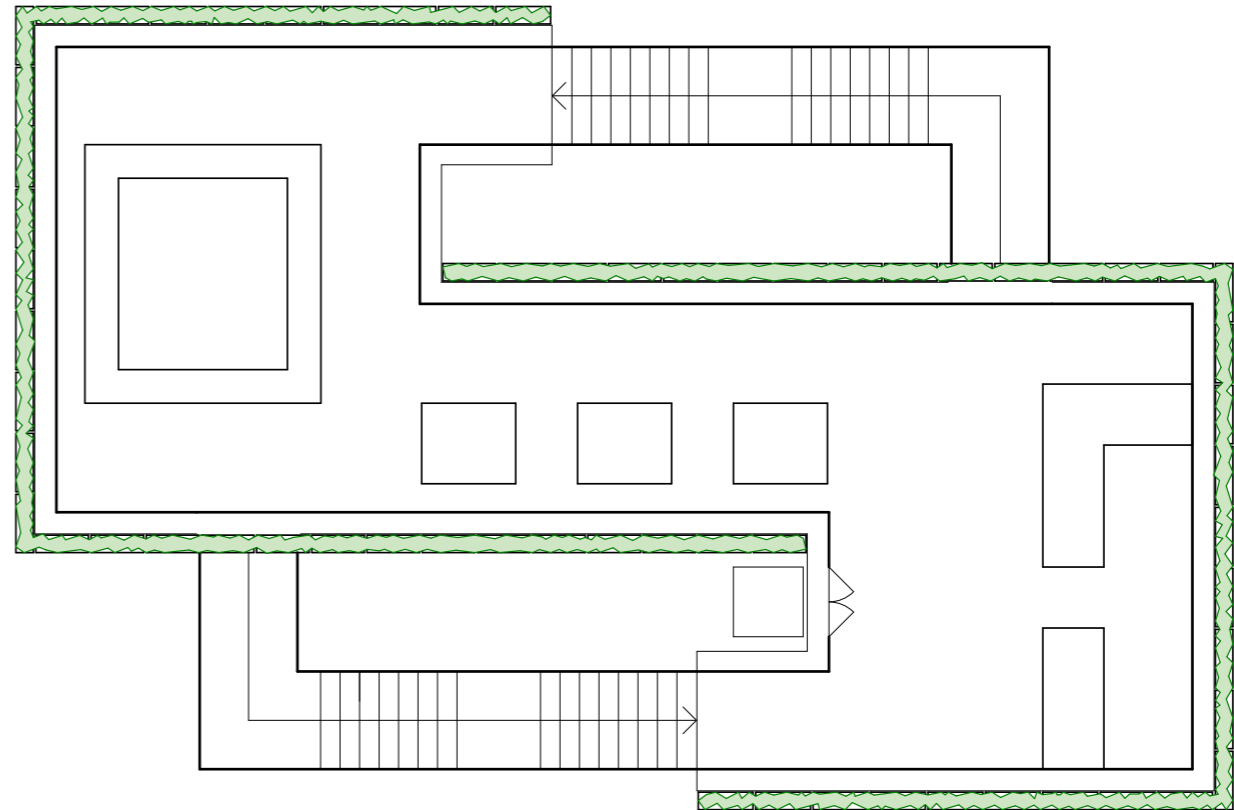

Dachgeschoss

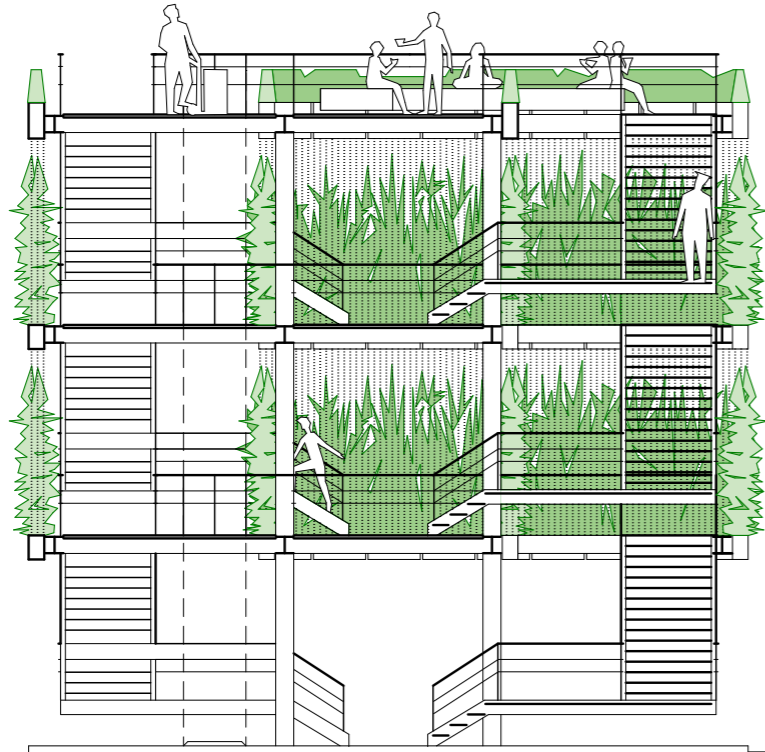

Querschnitt

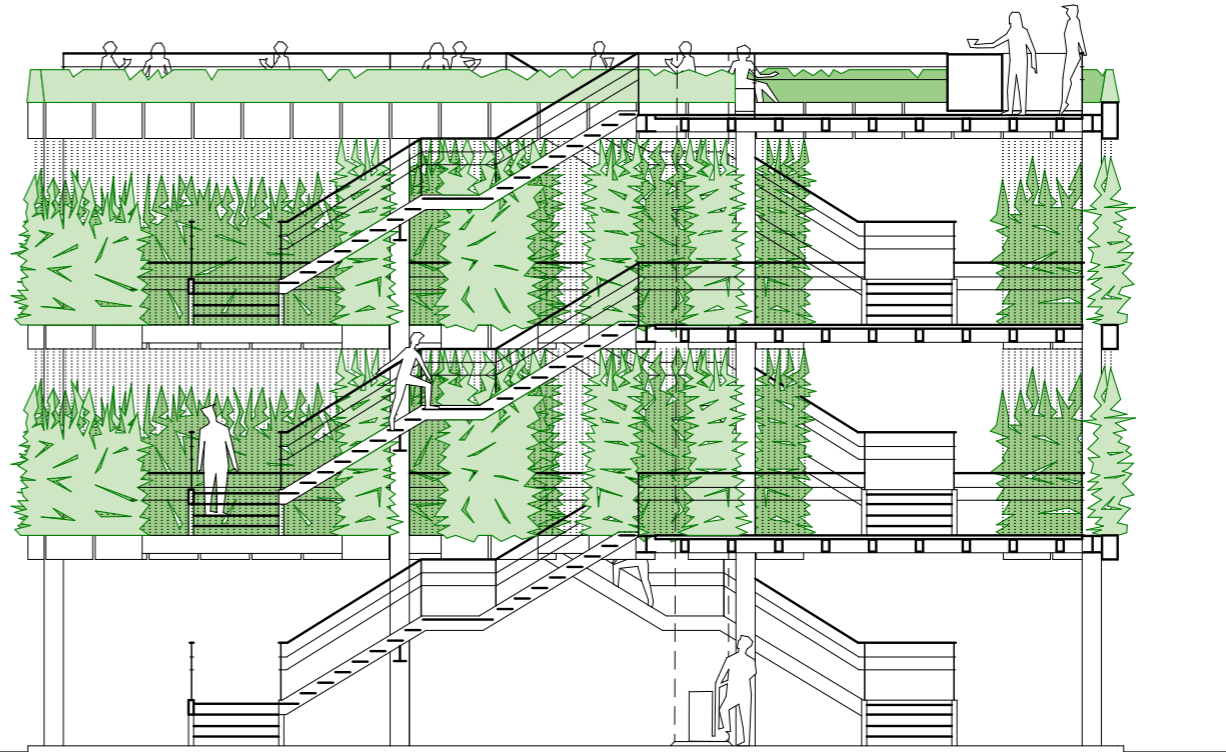
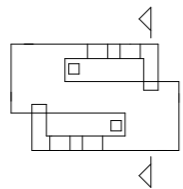

Längsschnitt

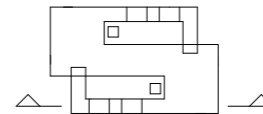

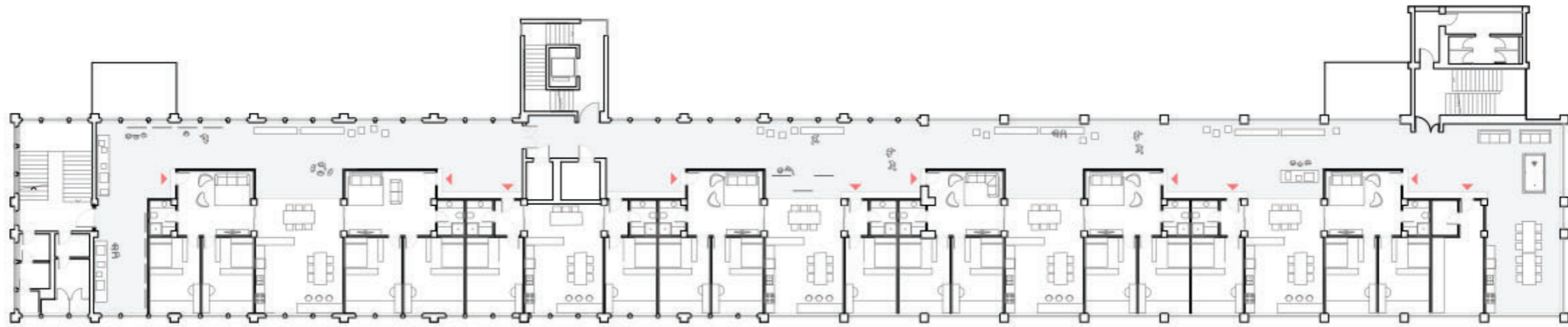

Grundriss



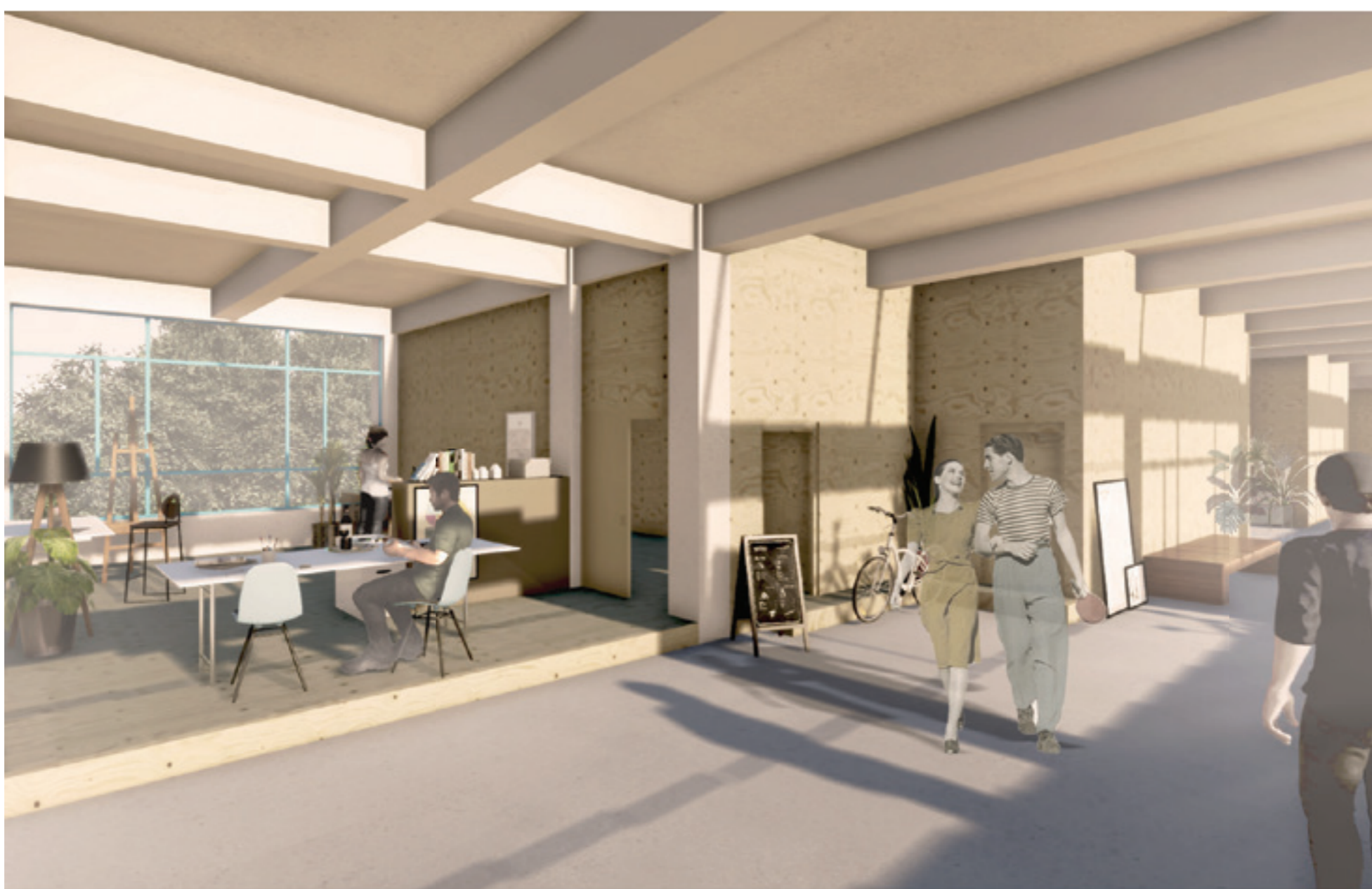

X.CAMPUS
Bauformenlehre
Emilia Hernández
Timmy Yang



Schnitt 1



Schnitt 2



X.CAMPUS
Bauformenlehre
Emilia Hernández
Timmy Yang

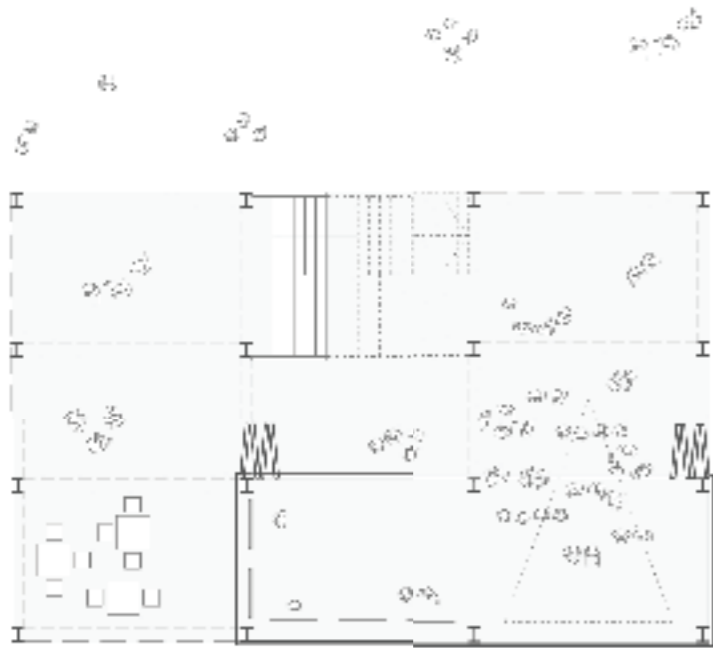

Erdgeschoss



1.Obergeschoss

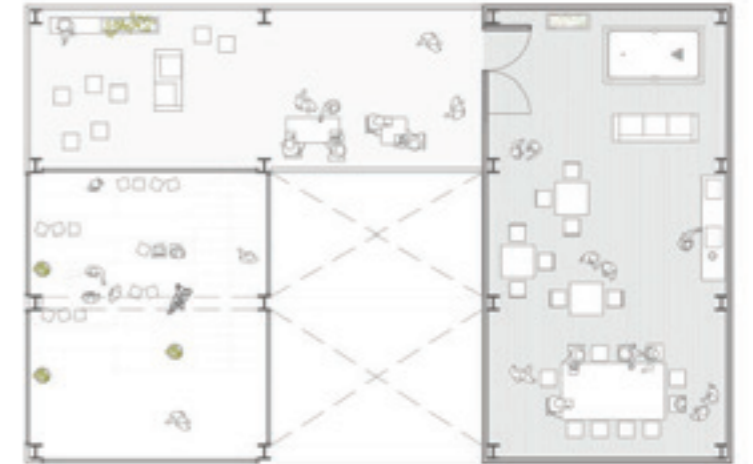

2.Obergeschoss

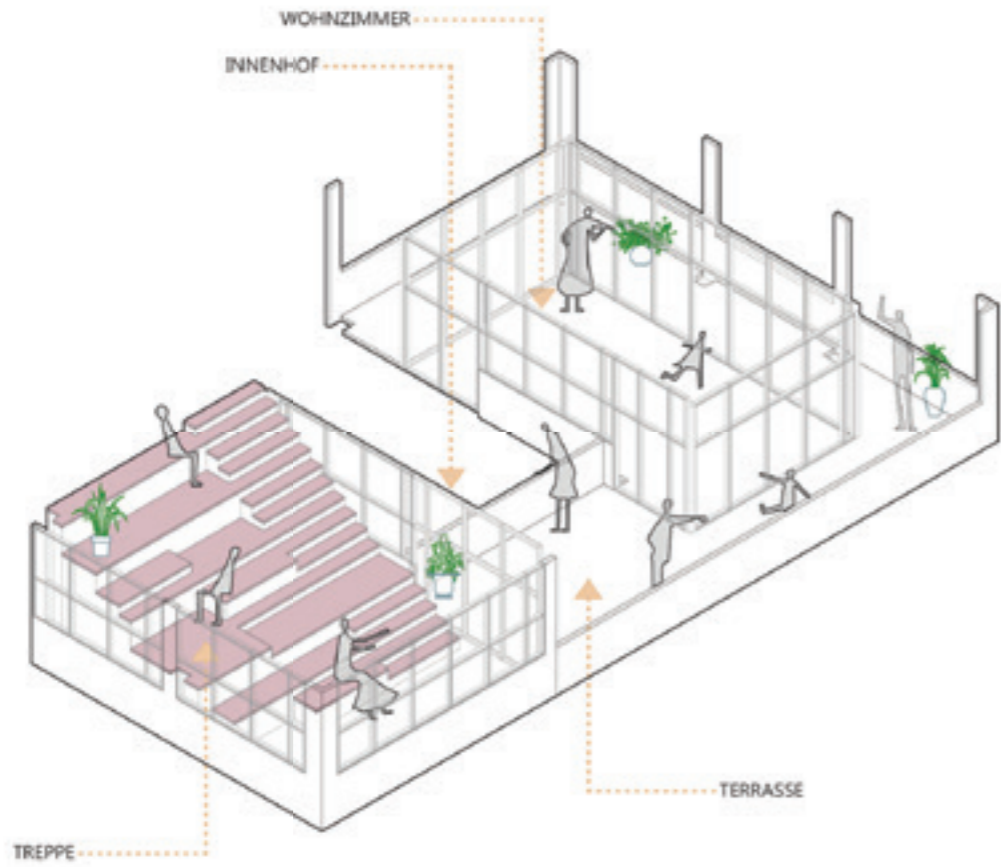

Isometrie



Detail

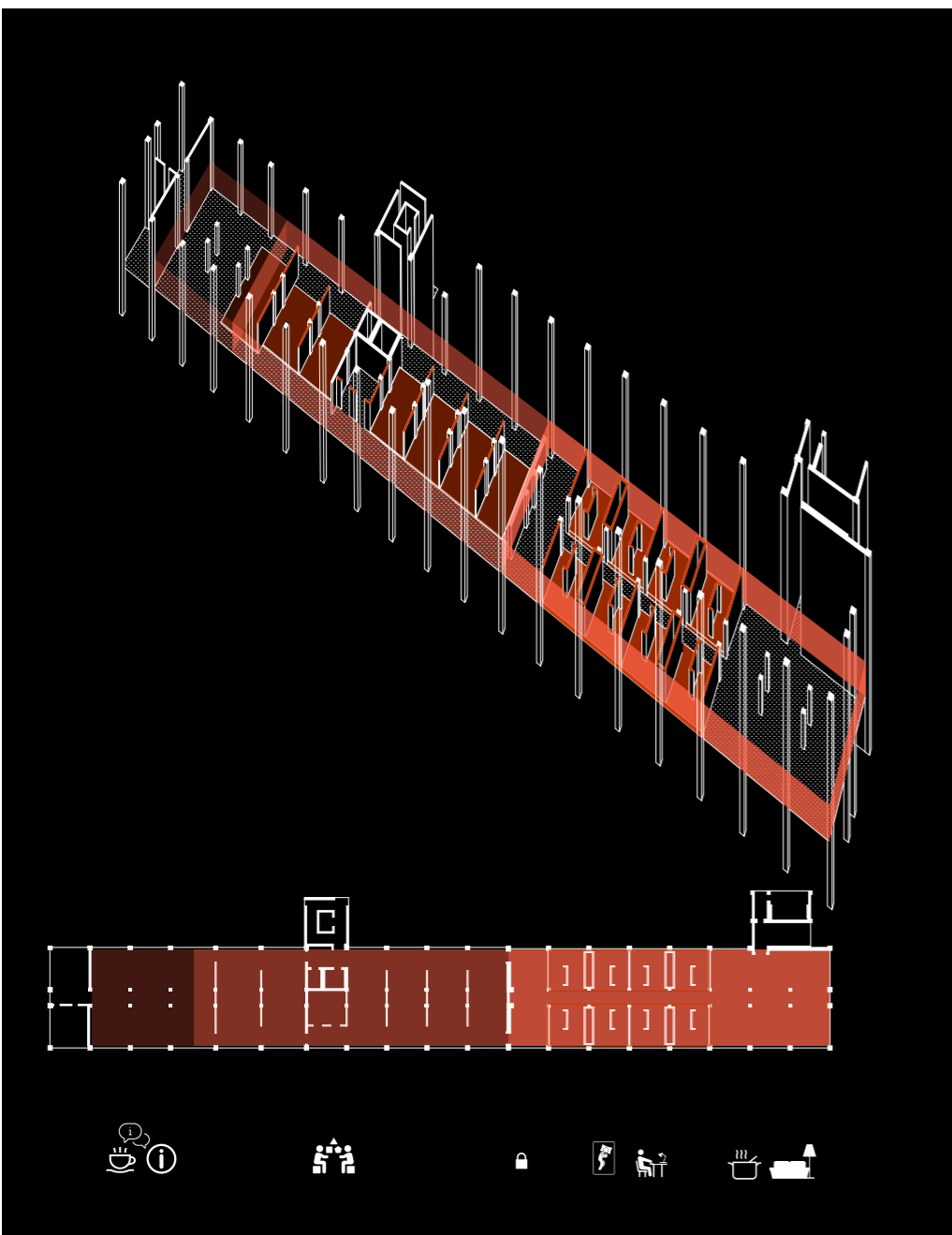

Konzept + Axonometrie

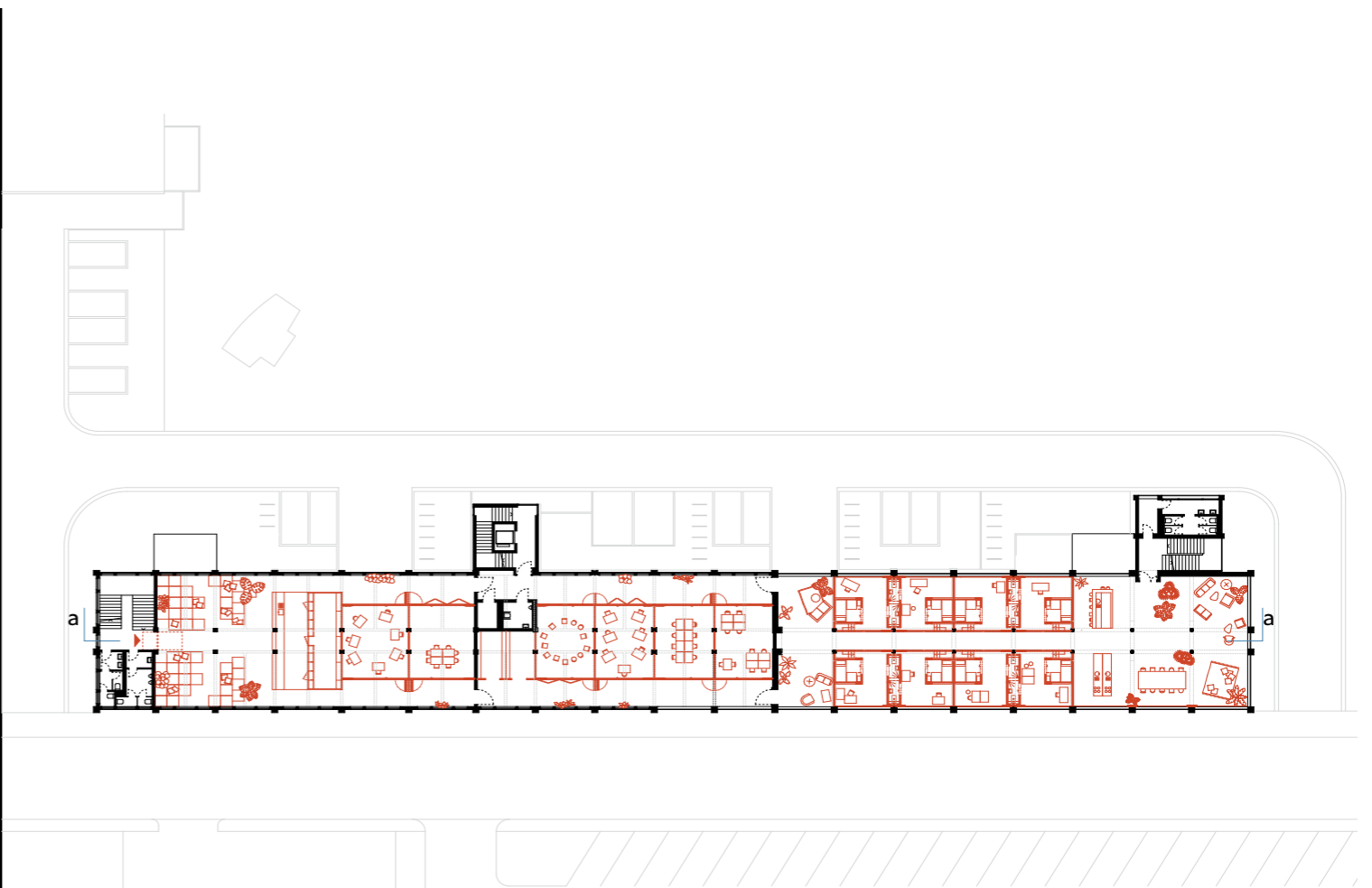

1. Obergeschoss

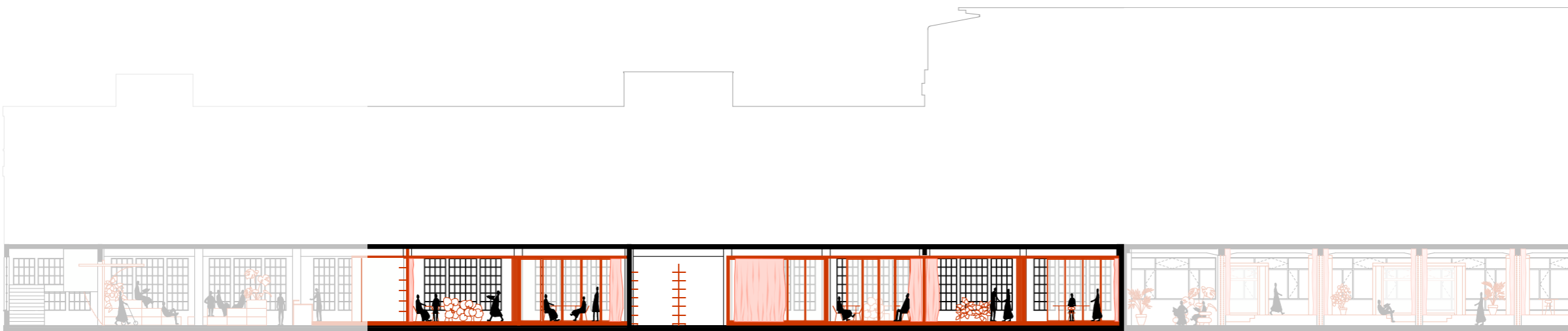

Schnitt 2.Stufe

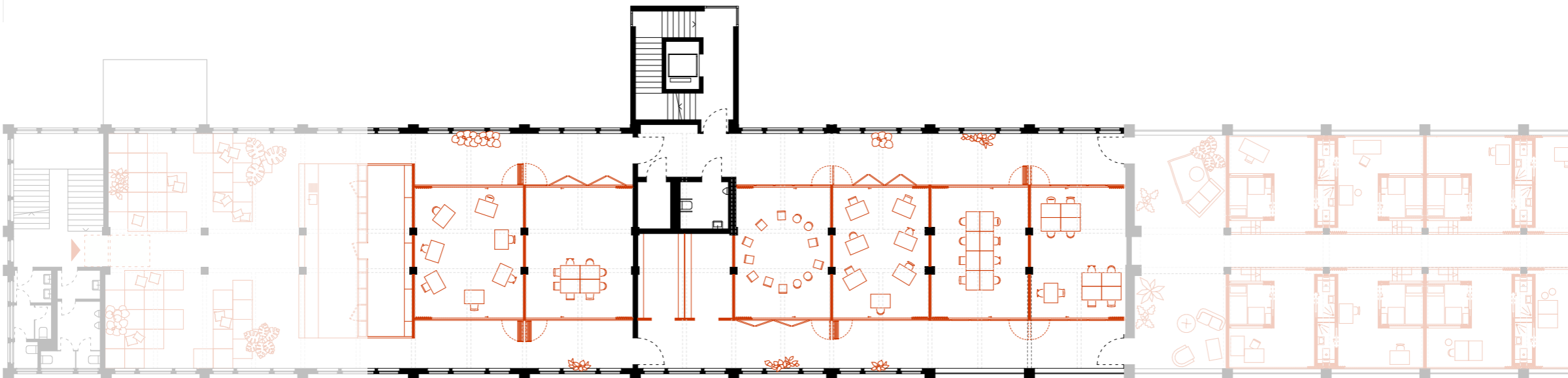

Grundriss 2.Stufe

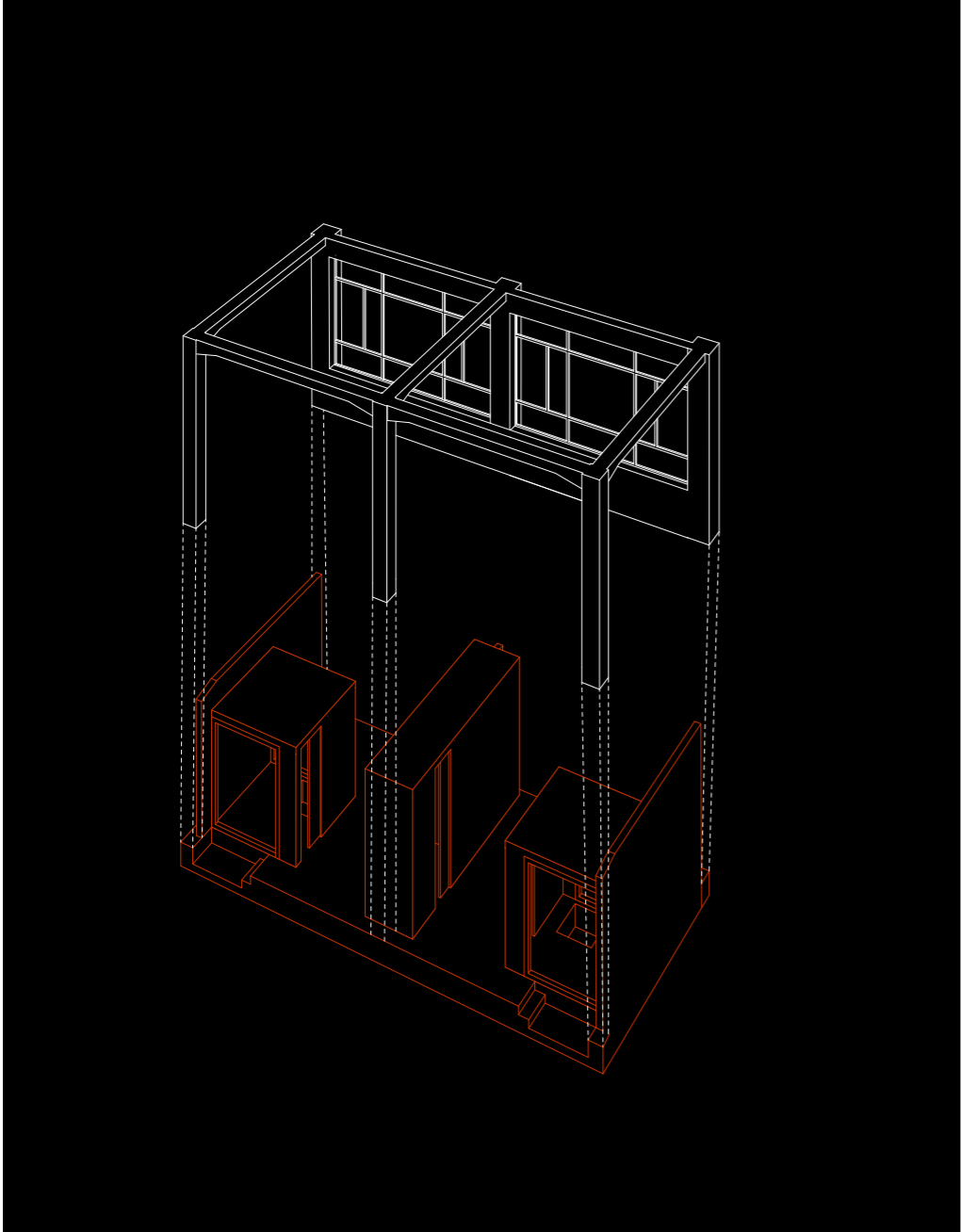

Wohnkapsel Axonometrie

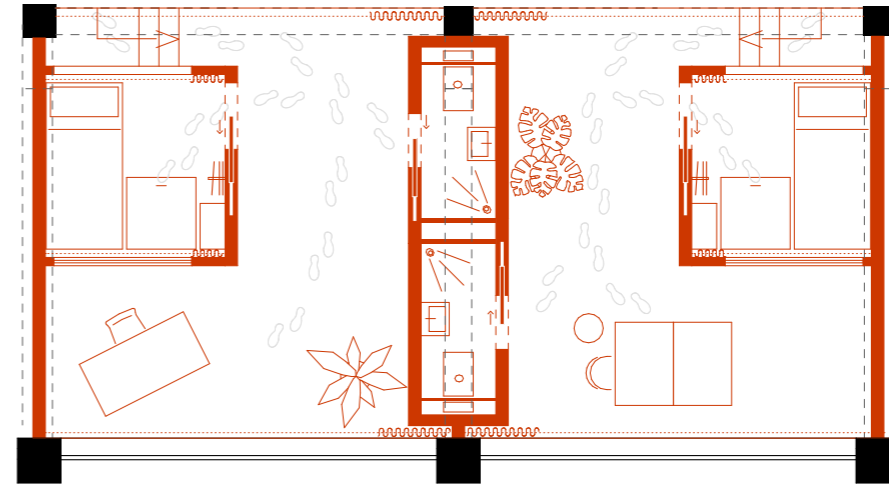

Wohnkapsel Grundriss

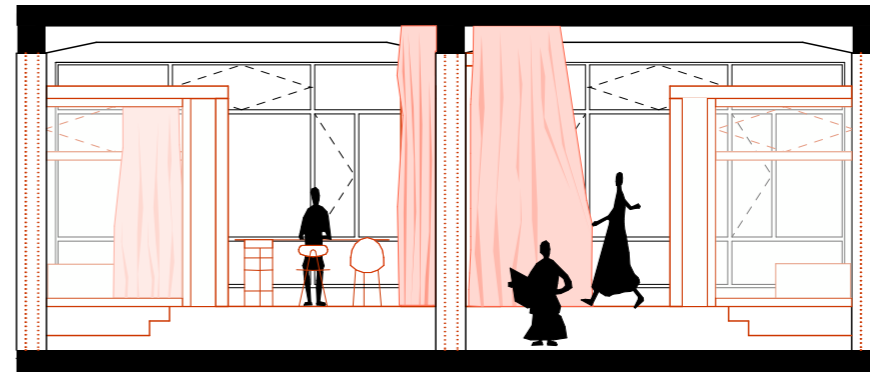

Wohnkapsel Schnitt



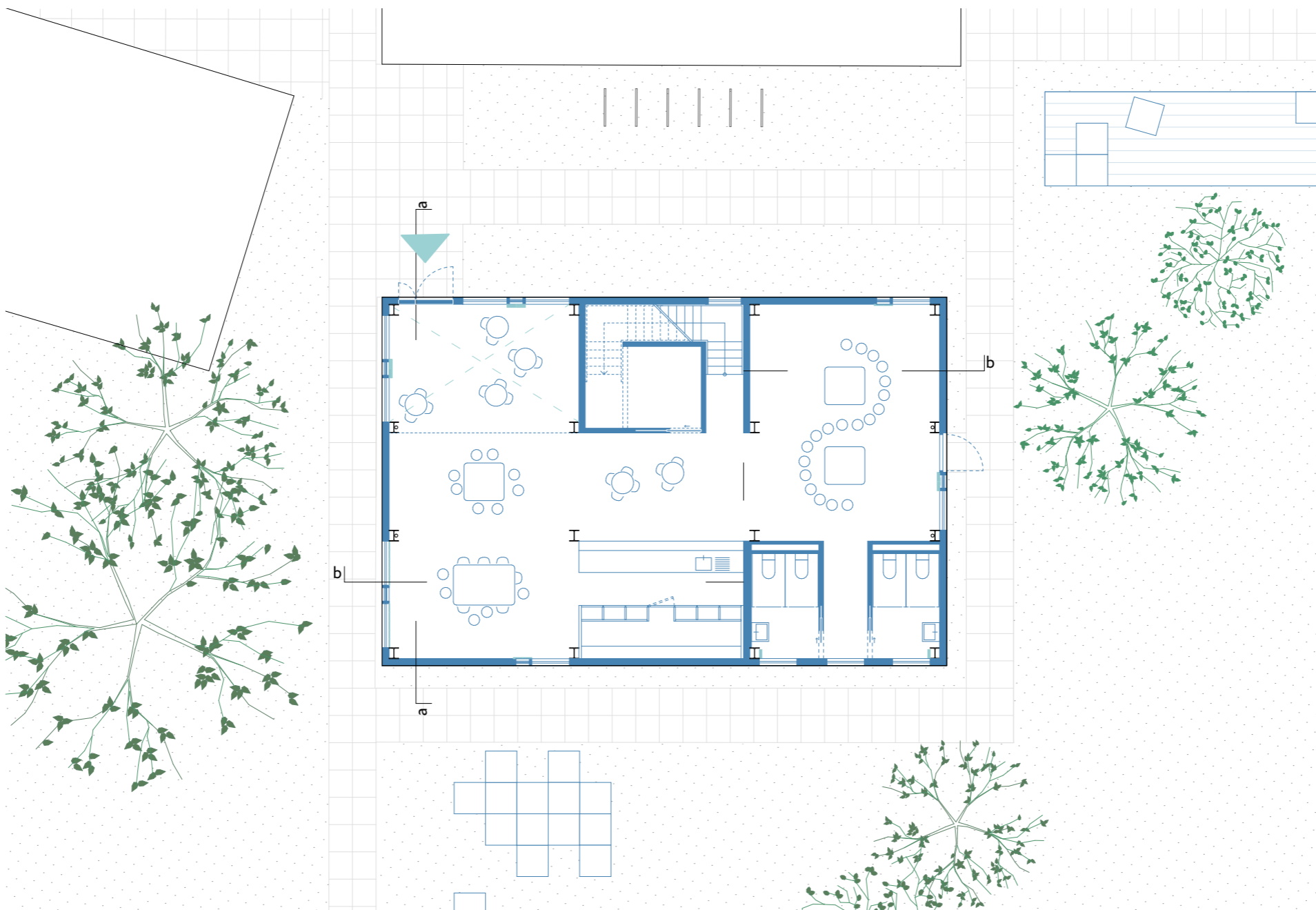

Erdgeschoss

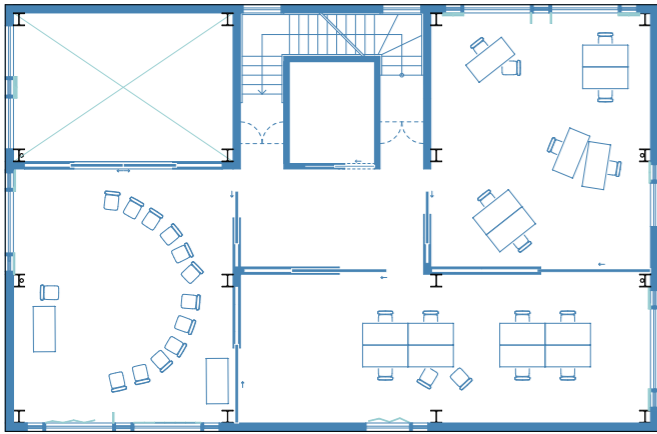

1.Obergeschoss

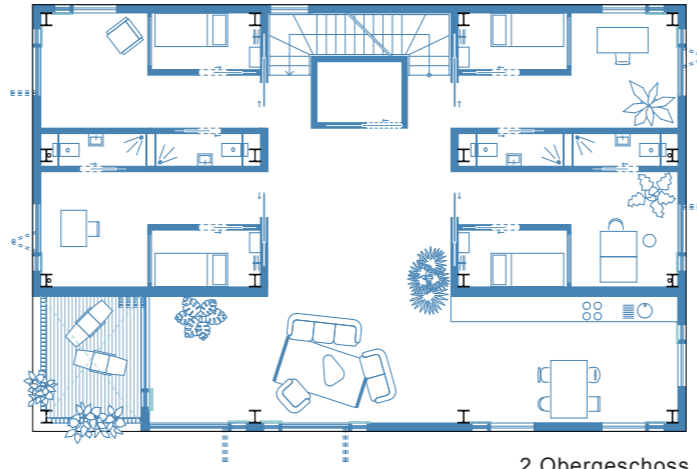

2.Obergeschoss

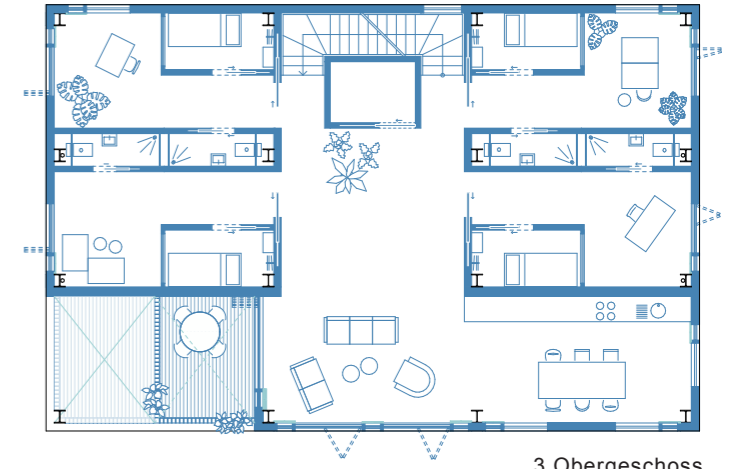

3.Obergeschoss

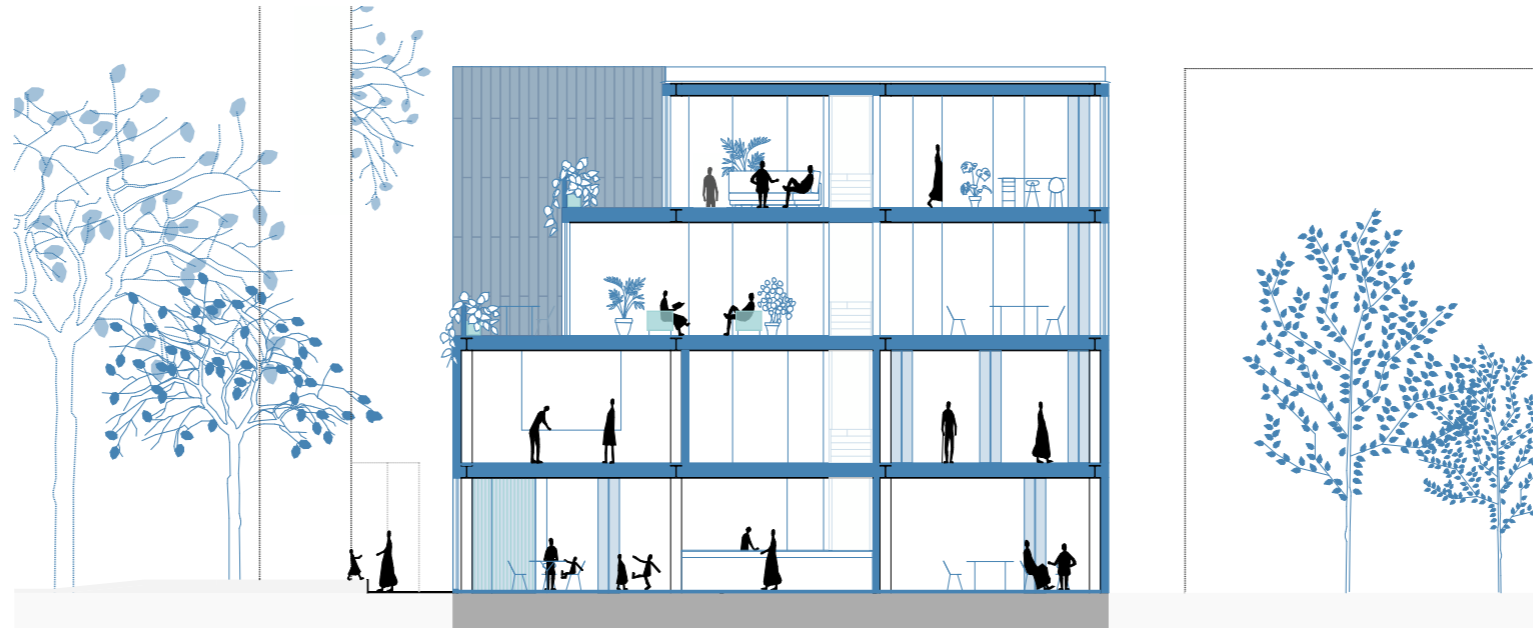

Schnitt

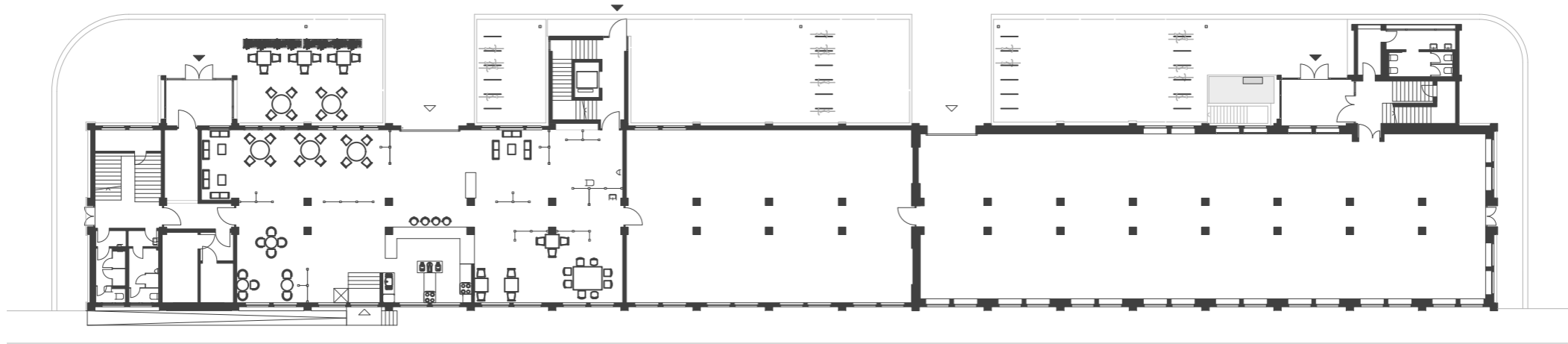

Erdgeschoss

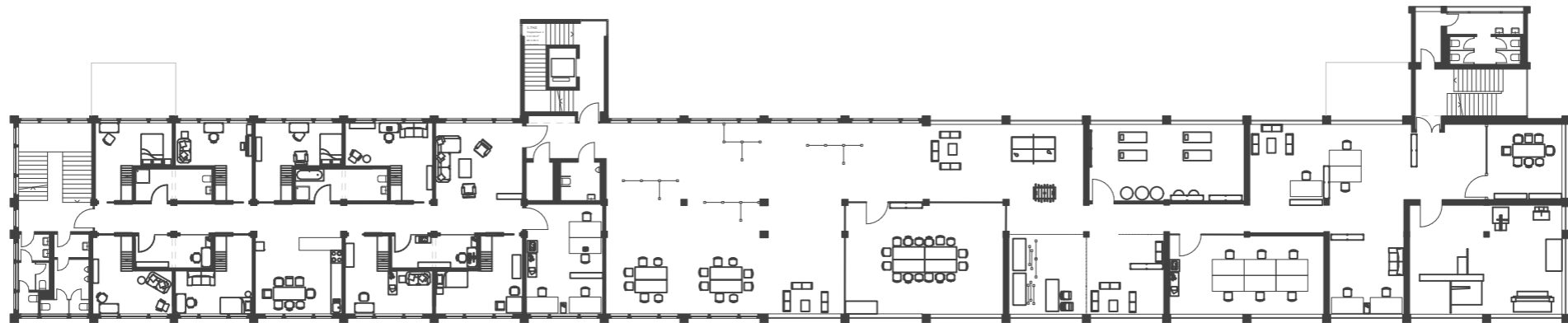

1.Obergeschoss

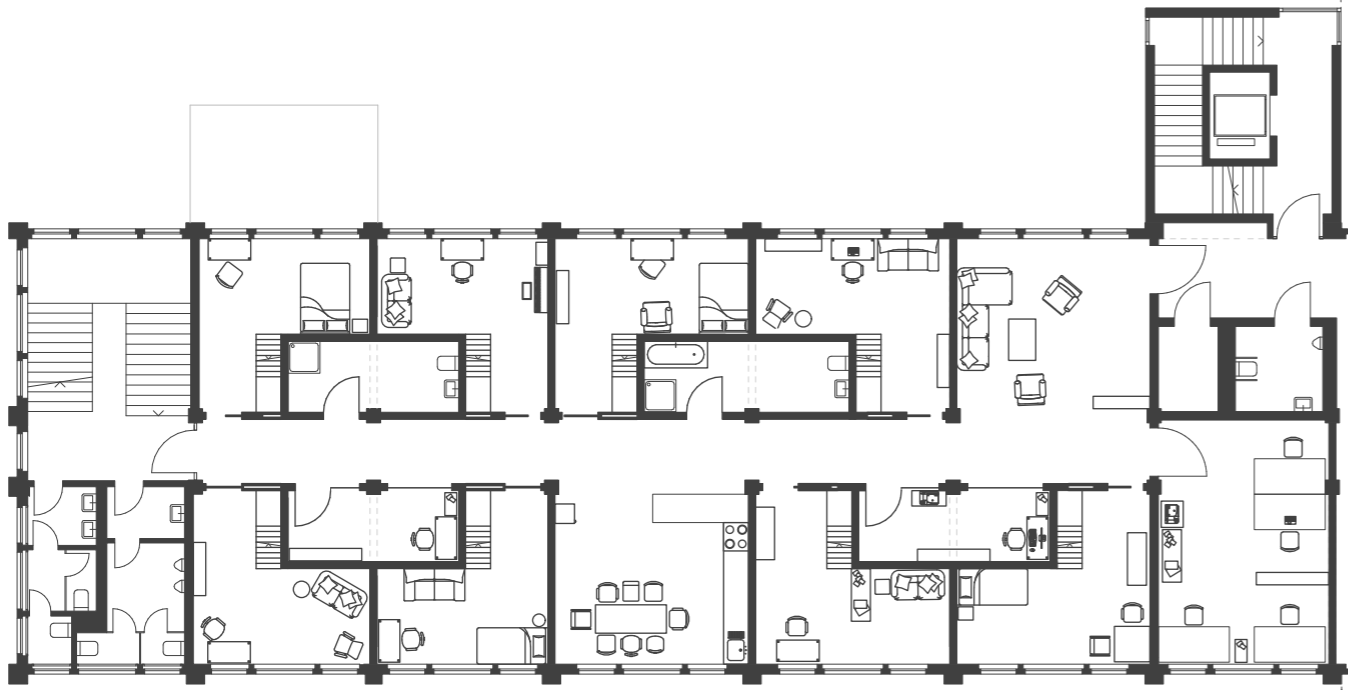

1.Obergeschoss Wohne



Schnitt Wohnen

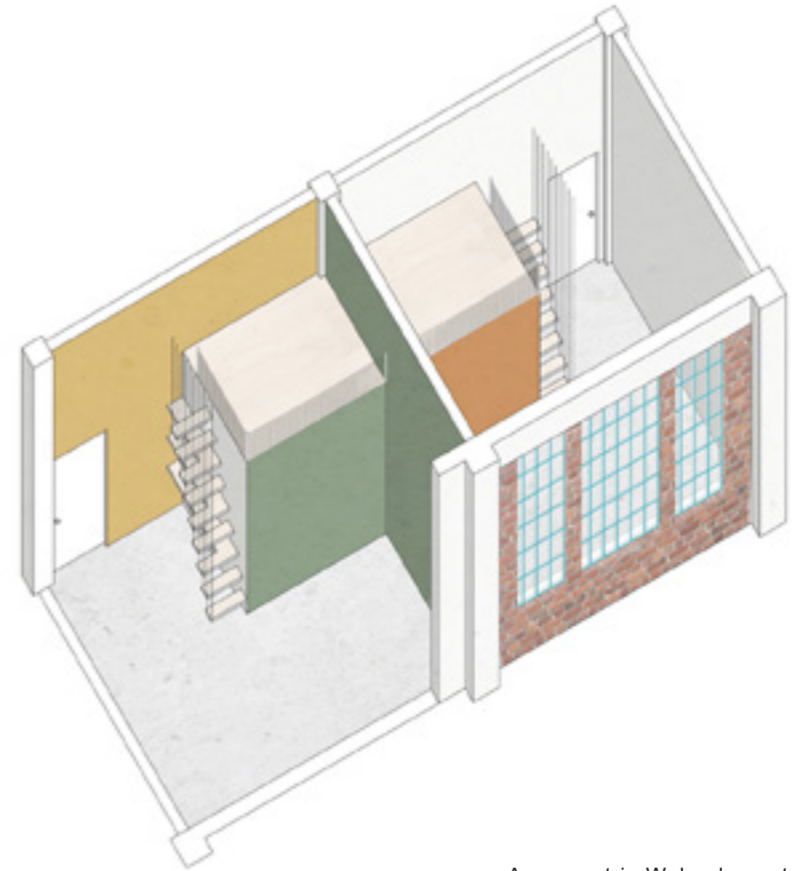

Axonometrie Wohnelement

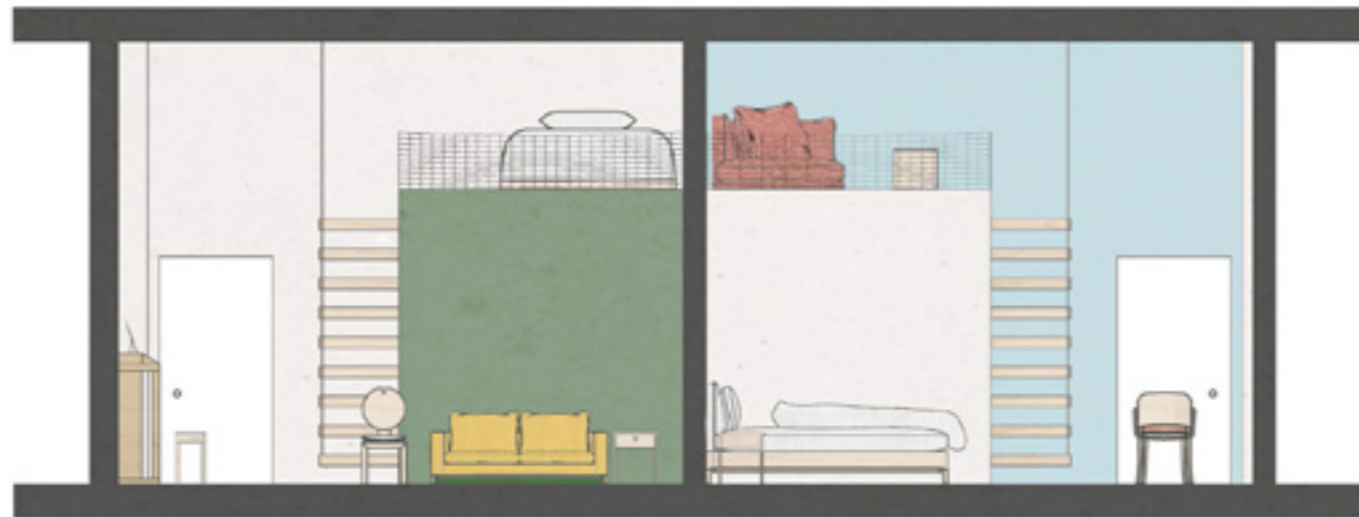

Schnitte Wohnelement



X.CAMPUS
Bauformenlehre
Clara Götsch
Leonie Kutz

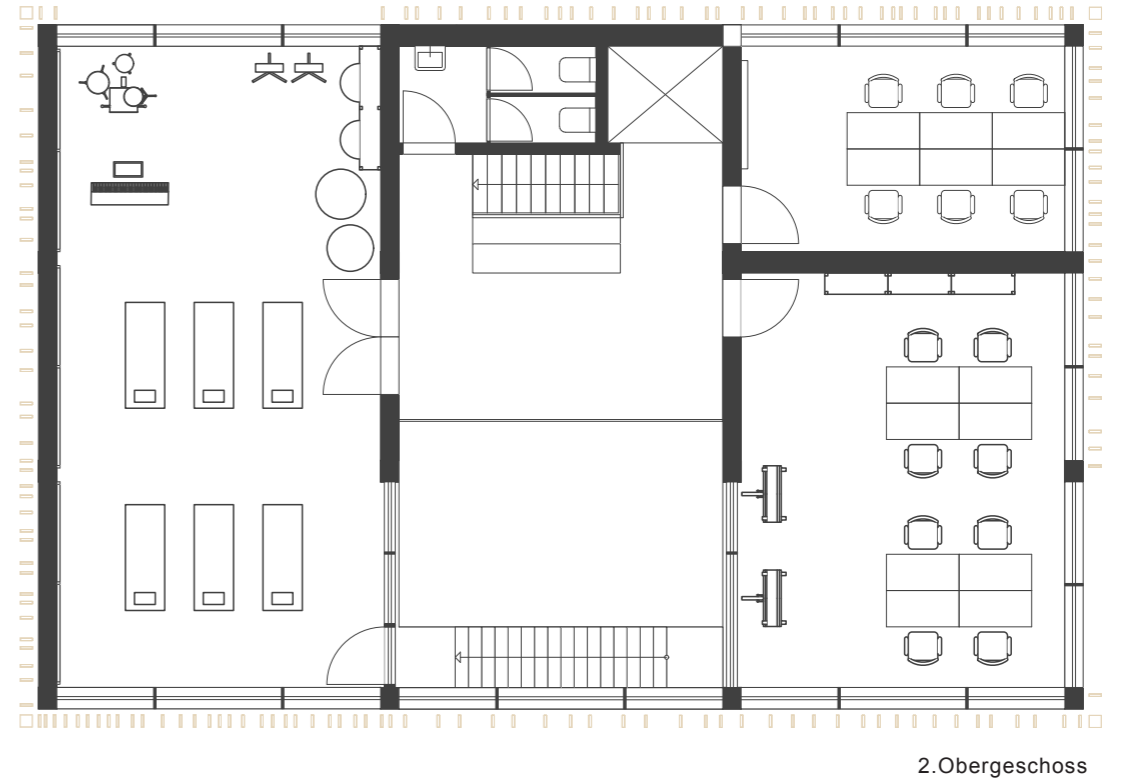
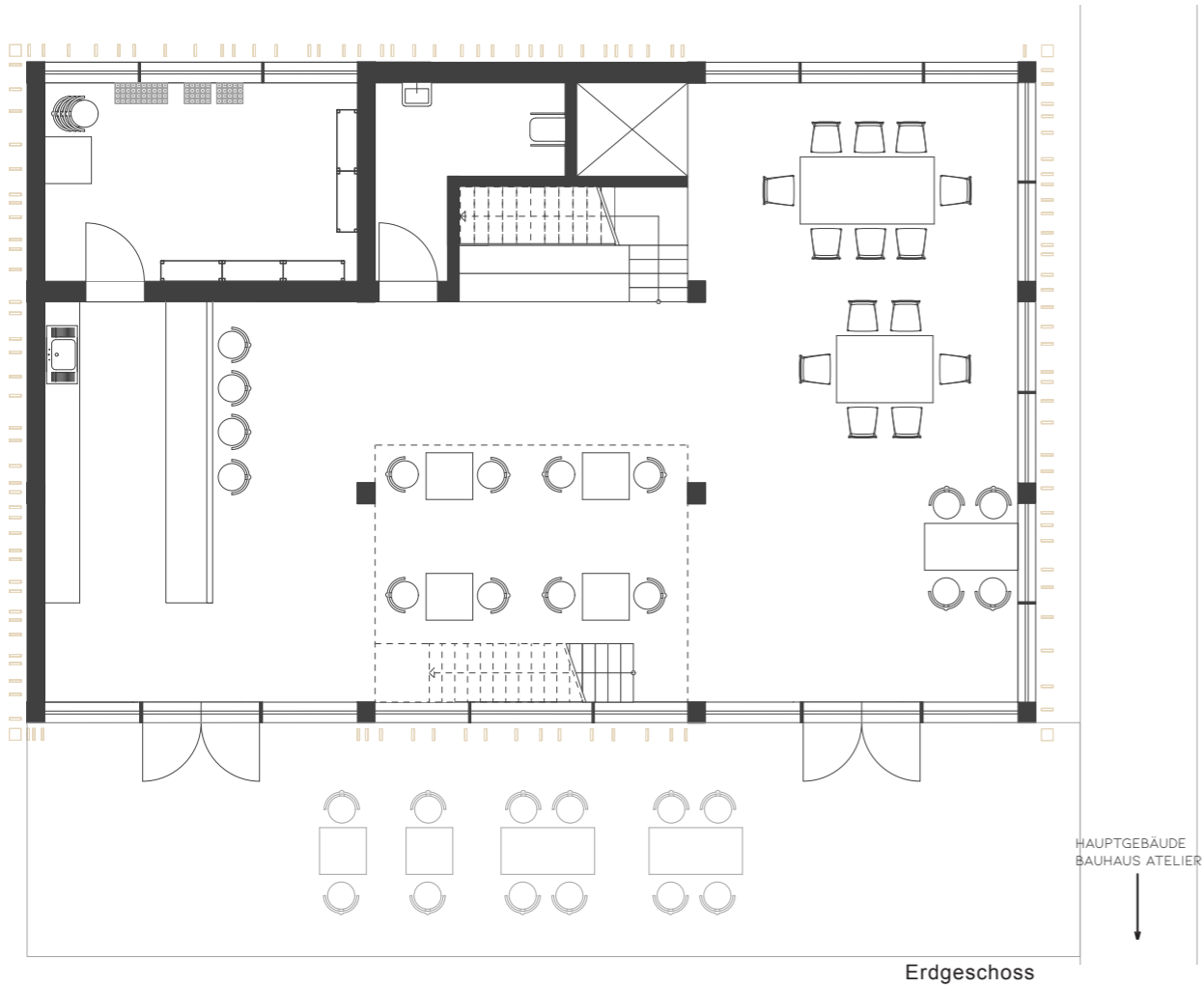

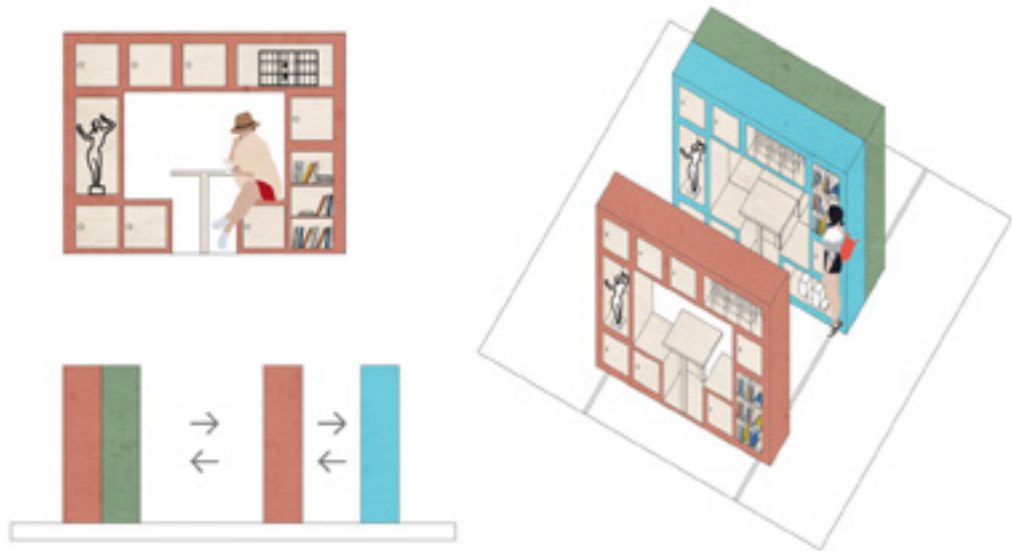

Verschiebbare Lernwand



Schnitt